

AirBorne

AUSTRALIA

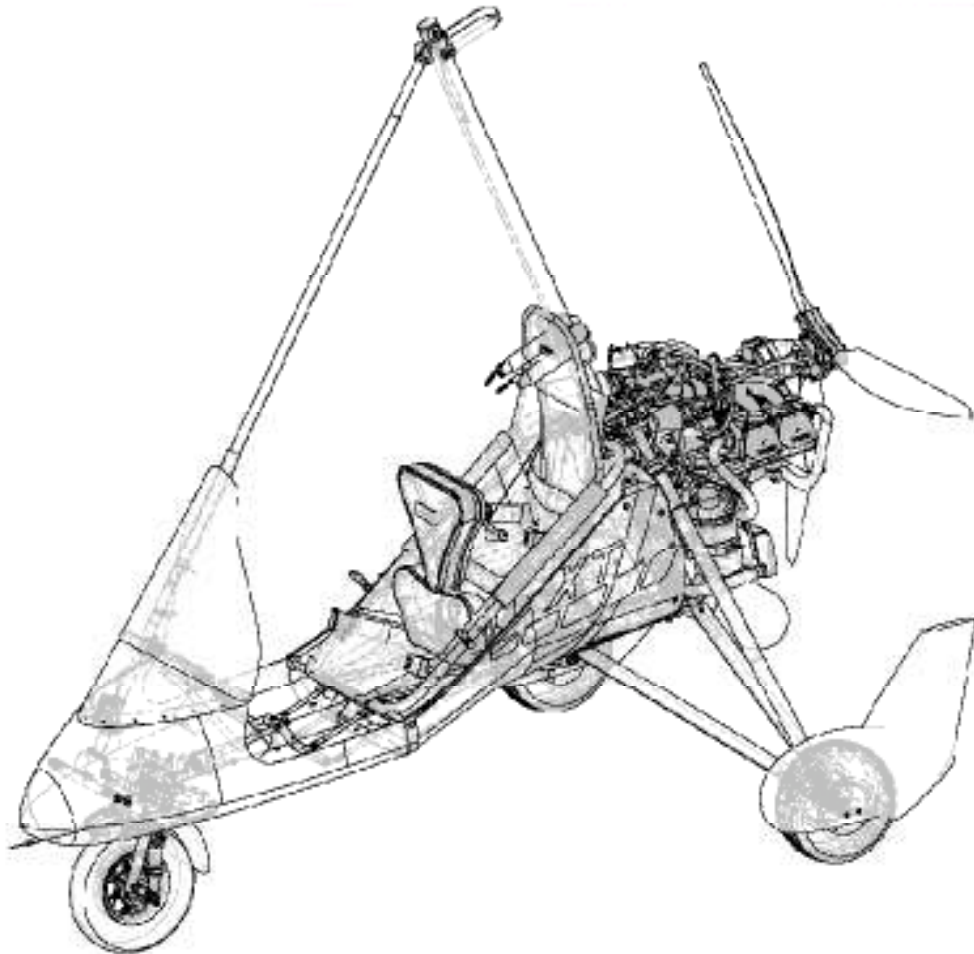

XT 912 MAINTENANCE MANUAL ISSUE 1.2

Manufacturer: AirBorne WindSports Pty Ltd
Unit 22/30 Kalaroo Rd
Redhead, NSW
Australia

Phone : + 61 2 4944 9199
Fax : + 61 2 4944 9395
Website : www.Airborne.com.au

Part # 107612

DATA PACKAGE

This manual constitutes one part of the complete data package that accompanies the aircraft. Following is a list of each of the components which are required.

- **Pilot’s Operator’s Handbook or Aircraft Operating Handbook**
- **XT 912 Maintenance Manual**
- **XT 912 Illustrated Parts Catalogue**
- **Wing Maintenance Manual**
- **Wing Illustrated Parts Catalogue**
- **Rotax Owners Manual**
- **Rotax Maintenance (Compact Disk)**
- **Radio Manual – If Installed**
- **BRS Parachute Manual – If Installed**
- **Transponder Manual – If Installed**

+

Table 1 XT 912 Data Package

INTRODUCTION

This manual contains factory recommended procedures and instructions for ground handling, servicing and maintaining the XT 912 Base section of this aircraft. The procedures described are to be used in conjunction with the National Airworthiness Authority (NAA) of the country of registration. Any NAA maintenance requirement takes precedence over this manual.

This manual will be used in conjunction with a certified wing, and therefore the operator is directed to reference the wing maintenance manual for any issues that are related to the wing component of the aircraft.

Skills

Only people with an adequate skill level should perform maintenance on this aircraft. A sound understanding of mechanical systems, and good experience with the necessary tools and procedures is required - as the continuing airworthiness of the aircraft relies on the competence of the person performing the maintenance. Assessment and judgement of the condition of each individual component is required, which necessitates a sound understanding of the purpose of each component in the system. All maintenance and repairs must be carried out in accordance with good aeronautical practices.

Skills and authorisations specific to Special Light Sport Aircraft

Maintenance tasks are rated in the categories listed below, according to the applicable category of registration and skill levels required to perform those tasks:

Owner— FAA regulations authorize SLSA aircraft owners who hold at least a sport pilot certificate to perform maintenance as outlined in 14 CFR Part 43. To perform inspections on aircraft condition, functional checks and maintenance in between inspections carried out by LSA Repairman Maintenance certificate holders.

LSA Repairman Maintenance— This certification authorizes a certificate holder to perform line maintenance, repairs and alterations to S-LSA as the task allows. Includes 100 hourly and yearly inspections on S-LSA.

A&P—Mechanic Certificate with Airframe and or Powerplant rating. To perform heavy Maintenance on airframes or powerplant as the rating allows.

Task Specific—Applicable to the following ratings:

LSA Repairman Maintenance with appropriate task specific training or;

A Mechanic Certificate with appropriate task specific training.

Authorizes the holder of mechanic certificate or a repairman certificate who has received task specific training, to perform the tasks approved under that training. Allows a repairman certificate holder to perform, heavy maintenance, repairs and alterations on the SLSA.

E.g. The Mechanic Certificate holder may obtain Task Specific training on Rotax engines, to allow overhaul etc.

Skills and authorisations specific to Experimental Special Light Sport Aircraft

LSA Repairman Inspection— To perform line maintenance and inspections to be completed on an E-LSA by a responsible owner, who holds an FAA repairman certificate (light sport aircraft), with an inspection rating or equivalent.

There are no requirements for minimum certification to perform any other task on an experimental aircraft. However, Airborne recommend that only people with an adequate skill level should perform maintenance on this aircraft as described at the start of this section.

Other Categories of Registration

This aircraft is certified as a Primary Category aircraft and when supplied with this manual and associated placards is a Light Sport eligible aircraft. This manual is created to be compliant to the standards applicable to Special Light Sport Aircraft.

The category of registration may be quite varied; as such the maintenance requirements of this aircraft are to be applied in conjunction with the requirements of the National Airworthiness Authority (NAA) of the country of registration. Any NAA maintenance requirement takes precedence over this manual.

In the event that the owner is permitted to perform maintenance in their country and category of registration, if there are any doubts regarding the required and appropriate maintenance then the safety of the aircraft may be jeopardised in continuing with self maintenance. In this situation an Airborne Dealer should be contacted for the correct procedures and or servicing.

Tooling

There are no specialised tools (except for the air shocks) needed for the maintenance described in this manual, following is a list of the type of tools that may be required. Nb. Loctite will be required in certain locations and should **always** be replaced after disassembly.

- **Loctite (243, 567 and Antisize Lubricant # 76764) For the frame section.**
- **The Rotax Maintenance Manual gives a list of consumable materials in section 2.5.**
- Ring / Open ended Imperial Spanner set
- Ring / Open ended Metric Spanner set
- Torque wrench

WARNING

SPECIALISED PUMPS MUST BE USED FOR THE AIR SHOCKS – PRESSURES UP TO 600 PSI EXIST.

- Air Pump (Schrader Style Valve)
- Various petroleum lubricants
- Dry Lubricant – lubricant which doesn't attract dust after application.
- Tie wire, and tooling
- Wire and Swages and tooling
- Hex key set (metric and imperial)
- Petrol resistant thread sealant tape
- Various general care items

This list may not be comprehensive.

Service Difficulty Reporting

Any service difficulties or defects should be reported to Airborne using the form contained in appendix A.

WARNING

REPAIRS SHOULD NOT BE CONDUCTED UPON THE FOLLOWING ITEMS AS THEIR STRUCTURAL INTEGRITY IS CRITICAL TO SAFETY.

THE MAST STRUCTURES, HANG POINT, BASE BEAM, FRONT FORK ATTACHMENT ASSEMBLY, LANDING GEAR STRUTS.

OTHER MINOR REPAIRS CAN BE CARRIED OUT IN ACCORDANCE WITH FAA AC 43.13 1B

Format

The manual has been prepared using the ATA format, which provides a standard layout of the chapters to be included, and their content. Some of the chapters are not included as they are deemed to be not applicable to this aircraft. The content is compliant with Light Sport Aircraft standard. Skill levels required to perform tasks are applicable to the levels of qualification issued under the Light Sport Aircraft System.

The information in this manual is based on the data that was available at the time of its publication. The latest amendments to this manual will be issued on the Airborne website in PDF format. This should be printed out and added to the manual. Therefore it is important that operators keep a regular check on the website for any amendments that have been made. If any errors or omissions are found in this manual please advise the factory.

WARNING

THE INFORMATION IN THIS MANUAL NEEDS TO BE FOLLOWED, AND IT IS NOT ACCEPTABLE TO MAKE CHANGES TO THE MATERIALS AND OR PHYSICAL FEATURES OF THIS AIRCRAFT. IN PARTICULAR THE GRADES OF BOLTS THAT HAVE BEEN UTILISED IN THE MANUFACTURE OF THIS AIRCRAFT ARE CRITICAL FOR ITS CONTINUING AIRWORTHINESS. NEVER REPLACE BOLTS WITH ANY OTHER SIZE OR GRADE. GRADE 8 BOLTS ARE NOT INTERCHANGEABLE WITH AIRCRAFT (AN) GRADE BOLTS. THE FATIGUE CHARACTERISTICS OF AIRCRAFT GRADE BOLTS ARE SUPERIOR TO OTHER BOLTS AND ALLOW LONGER SAFE SERVICE LIFE UNDER CYCLIC LOADS LIKE THOSE EXPERIENCED IN AIRCRAFT. THE LENGTH OF BOLT IS IMPORTANT. IF A SHORTER BOLT IS USED THE THREAD MAY ENCROACH ON THE LOAD BEARING AREA, WHICH INCREASES THE STRESSES EXPERIENCED BY IT.

MANDATORY SERVICE BULLETINS

AS THE SERVICE HISTORY OF THE AIRFRAME EVOLVES AIRBORNE WILL FROM TIME TO TIME ISSUE MANDATORY SERVICE BULLETINS, WHICH DETAIL ANY CHANGES TO THE MAINTENANCE MANUALS, PILOT'S OPERATING HANDBOOK, OR ANY OTHER DETAILS THAT AIRBORNE DEEMS NECESSARY FOR OWNERS TO BE NOTIFIED OF.

THE WEB ADDRESS FOR SERVICE BULLETINS IS:

[HTTP://WWW.AIRBORNE.COM.AU/](http://www.airborne.com.au)

IT IS THE RESPONSIBILITY OF THE OPERATOR TO KEEP UP TO DATE WITH ANY ROTAX DIRECTIVES THROUGH THE ROTAX WEBSITE.

USE OF METRIC/ IMPERIAL UNITS

This Service Manual uses the metric unit system as the basic system of measurement. Where common usage or available instrumentation refer to, the Imperial system, both units are quoted. The following conversion factors are presented as a ready reference to the conversion factors that have been used in this manual.

1 Pound (lb)	=	0.4536 Kilogram (kg)
1 Pound per sq in (psi)	=	6.895 Kilopascal (kPa)
1 Inch (in)	=	25.4 Millimetres (mm)
1 Foot (ft)	=	0.3048 Metre (m)
1 Statute mile	=	1.609 Kilometres (km)
1 Nautical mile (NM)	=	1.852 Kilometres (km)
1 Millibar (mb)	=	1 Hectopascal (hPa)
1 Millibar (mb)	=	0.1 Kilopascal (kPa)
1 Imperial gallon	=	4.546 Litres (l)
1 US gallon	=	3.785 Litres (l)
1 US quart	=	0.946 Litre (l)
1 Cubic foot (ft ³)	=	28.317 Litres (l)
1 Degree Fahrenheit (F)	=	(1.8 X C)+32
1 Inch Pound (in lb)	=	0.113 Newton Metres (Nm)
1 Foot Pound (ft lb)	=	1.356 Newton Metres (Nm)

Table 4 Imperial / Metric Conversions

CONTENTS

DATA PACKAGE.....	2
INTRODUCTION.....	5
MANDATORY SERVICE BULLETINS.....	7
LIST OF TABLES.....	10
LIST OF FIGURES.....	10
0. ASSEMBLY AND TEST FLIGHT / COMPONENT OVERVIEW.....	12
4. AIRWORTHINESS LIMITATIONS.....	17
5. TIME LIMITS/MAINTENANCE CHECKS.....	18
5. TIME LIMITS/MAINTENANCE CHECKS.....	18
6. DIMENSIONS AND AREAS.....	28
7. LIFTING AND SHORING.....	30
9. TOWING AND TAXIING.....	31
10. PARKING AND MOORING.....	34
11. REQUIRED PLACARDS.....	36
12. SERVICING.....	37
23. COMMUNICATIONS.....	53
24. ELECTRICAL POWER.....	54
25. EQUIPMENT/FURNISHINGS.....	55
27. FLIGHT CONTROLS.....	56
28. FUEL SYSTEM.....	57
31. INDICATING/RECORDING SYSTEMS.....	65
32. LANDING GEAR.....	67
34. NAVIGATION AND PITOT STATIC.....	72
53. FUSELAGE.....	74
55. STABILIZERS.....	78
56. WINDOWS.....	79
61. PROPELLERS.....	80
71. POWER PLANT.....	92
72. ENGINE MAINTENANCE.....	94
73. ENGINE FUEL SYSTEMS.....	96
74. IGNITION.....	97
76. ENGINE CONTROLS.....	98
77. ENGINE INDICATING.....	100
79. OIL.....	103
80. STARTING.....	104
95. SPECIAL PURPOSE EQUIPMENT.....	104
APPENDIX A – Condition Inspection Checklist.....	105
APPENDIX B – Feedback Form.....	106

LIST OF TABLES

Table 1 XT 912 Data Package.....	2
Table 2 Amendment Record Sheet.....	3
Table 3 Log Of All Effective Pages, Issue 1	4
Table 4 Imperial / Metric Conversions.....	8
Table 5 Initial Assembly Procedure (GJP144)	12
Table 6 Airframe Limitations	17
Table 7 Time Limits of Components	18
Table 8 Maintenance Privileges.....	20
Table 9 Power Plant Maintenance Schedule	24
Table 10 http://www.rotec.com/whatnew.htm	25
Table 11 Torque Table	49
Table 12 Excerpt from GJP 141, Complete List of Tie Wire locations	50
Table 13 Fuel Tank Schematic.....	57
Table 14 Features of the Instrumentation	65
Table 15 SkyDAT Monitored Operations.....	100

LIST OF FIGURES

Figure 1 Main structural members	14
Figure 2 Cockpit	14
Figure 3 Under-seat bags	15
Figure 4 Mast Block Area	15
Figure 5 Steering and foot levers.....	16
Figure 6 Power plant.....	16
Figure 7 Front Mast to Mast Brace Check.....	26
Figure 8 Major Dimensions of the 912	28
Figure 9 Tie Down Hook Location.....	32
Figure 10 Front wheel with tie downs.....	32
Figure 11 Tie on Rear Wheel.....	33
Figure 12 Trike on Trailer	33
Figure 13 Parking of Trike (Upwind Wing Down)	34
Figure 14 Securing of Base Bar With Bungee.....	34
Figure 15 Parking Trike Tail to the Wind.....	35
Figure 16 Fuel Specifications.....	37
Figure 17 Rotax Oil Replenishment Service Release.....	40
Figure 18 Coolant Warning Sticker instructions, Excerpt, Rotax Service Bulletin SB-912-043, Sept 04.	41
Figure 19 Areas to be protected during cleaning.....	43
Figure 20 Seat Mast Block Sub Assembly	46
Figure 21 Outside Nut with spat bracket	47
Figure 22 Inside Nut and Inner Spat Bracket	47
Figure 23 View of Locking Bolt head.....	47
Figure 24 Tie Wires on Propeller	50
Figure 25 Rear Wheels Self Locking Nuts	50
Figure 26 Muffler Safety Wire and Springs	51
Figure 27 Mast Top Safetying.....	51
Figure 28 Finger Filter, as installed, as well as the unit prior installation.	60
Figure 29 Fuel Line Check Example.....	61
Figure 30 Fuel Flow Sender Device.....	62
Figure 31 Fuel Sender and tools.....	63
Figure 32 Fuel Tap Bracket Sub Assembly.....	64
Figure 33 SkyDAT Console Photo	65

Figure 34 Rear Shock Dimension Check	68
Figure 35 Front Shock Set up.....	69
Figure 36 Steering Damper Setting, (Dwg # 5610).	69
Figure 37 Front Wheel Assembly.....	70
Figure 38 Dynamic Port (Pitot Entry)	72
Figure 39 Top of Mast, attached to the wing	75
Figure 40 Front Landing Gear Attachment.....	76
Figure 41 Front Fork to Wheel Attachment	76
Figure 42 Rear Landing Gear and Engine Mount Attachment to Mast Block.....	76
Figure 43 Pod Front Attachment.....	77
Figure 44 Pod Attachment to Mast Brace	77
Figure 45 Pod Attachment to Seat Frame.....	77
Figure 46 Pod Instrument Panel Attachment	77
Figure 47 AN4 Bolts Into Forward Hub Block.....	81
Figure 48 Place Blades into Hub Block.....	82
Figure 49 Propeller with all the necessary components	82
Figure 50 Mounting the Propeller.....	83
Figure 51 Propeller AN4 Bolt Tightening Sequence Numbers	83
Figure 52 Propeller Part Lines	84
Figure 53 Shims under the front wheel	84
Figure 54 Prop Hub at 89.95 Degrees after correct shimming of front wheel	85
Figure 55 Propeller horizontal check.....	85
Figure 56 Radius Measurement.....	86
Figure 57 Setting the Blade to 70 Degrees at 24 inches	86
Figure 58 Propeller M8 Bolt Tightening Sequence Numbers.....	87
Figure 59 Tie Wiring Step 1.	88
Figure 60 Tie Wiring Step 2.	88
Figure 61 Correctly Installed Propeller	89
Figure 62 Engine Mount Rubbers	92
Figure 63 Top Rubber Link To Gearbox.....	93
Figure 64 Earthing of CHT Sender, to check the wire to the SkyDAT.	101
Figure 65 Photo of screwdriver in place to remove wire.....	102
Figure 66 Spare parts numbers for the XT912.....	102

0. ASSEMBLY AND TEST FLIGHT / COMPONENT OVERVIEW

00.00.00 Trike Base Assembly.

Line	Description	Ok
0	Find overhead support suitable to lift approx 200kg.	
1	Caution: Mast has an air strut and will move quickly when untethered!!	
2	Remove straps and box.	
3	Remove and unwrap all parts.	
4	Remove mast support screws from the crate – <u>leave the mast strap attached to base tube</u>	
5	Remove front axle tie down bolts from the crate.	
6	Loosen gearbox support rope.	
7	Un-bolt base tube support frame from the crate.	
8	Use lifting mechanism such as a small handwinch to lift rear of trike to allow assembly of rear end. Attach lifting device to gearbox hub using a soft sling. (Have someone hold trike in-case of roll over)	
9	Attach struts ensuring mast safety wire is attached	
10	Fit rear shocks to struts.	
11	Fit rear wheels and spat outer brackets. (Maintenance Manual Section 20.)	
12	Lower trike wheels to the ground and remove lifting device.	
13	Remove crate top, mast support (leave mast attached to base tube) and vertical legs. Remove crate base.	
14	Whilst holding down on mast remove strap and raise mast slowly.	
15	Attach mast brace inner tube to mast and tighten bolt (Wing Nut, Safety Pin)	
16	Secure mast outer sleeve with both pins at bottom.	
17	Raise front of trike using sling around base tube.	
18	Fit brake drum torque arm to stainless steel bush.	
19	Fit wheel in place	
20	Insert brake drum, spacers, axle, bolt and nuts. Lower trike	
21	Fit rear wheel spats. (Maintenance Manual Section 20.)	
22	Assemble prop and fit in accordance with Maintenance Manual Section 61.	
23	Tighten all nuts and bolts in accordance to standard practice (see maintenance manual)	
24	Carry out pre-flight inspection in accordance with the pilot handbook.	
25	Ensure the production flight test has been performed. Flight testing must be performed by an authorised Airborne Dealer. Airborne form GJP 170 to be completed and returned to Airborne by an Authorised Dealer.	

Table 5 Initial Assembly Procedure (GJP144)

This list is meant as a guide and is in no way a comprehensive list of instructions. Refer to Standard Practices, Section 20 for torquing procedures and refer to Illustrated Parts Catalogue to ensure complete and safe assembly is achieved.

Each of the components that have been disassembled, have the required nuts, bolts and washers in place - ready for fitment, this ensures that the reassembly is as easy as possible.

00.10.00 General

Spare Parts Service

Spare parts may be purchased from your local dealer. Visit the Airborne Website at :

<http://www.airborne.com.au/pages/dealerselect.cfm>

Accessed from the homepage under Microlights / Dealer listing.

Typical Consumables

100 hour service kit Airborne part number 106907

Contents of Rotax 912, 100 Hour Service Kit		Airborne part number 106907
Consumable	Airborne Part Number	Rotax Part Number
OIL SHELL ADVANCE 15W-50	106786	
ENGINE 912 OIL FILTER (Use only Rotax brand filter)	105620	825701
SPARKPLUG NGK DCPR7E	106816	
SILICONE HEAT TRANSFER PASTE	106817	897 186
WASHER 18X12X1 OIL TANK XT912	105936	Gasket Ring C12x18 #250010

Consumable	Airborne Part Number	External Supplier Part Number
TYRE 6" X 6.00 STANDARD	100268	15-600x6 4K01 TL Rib Part Number: 156006RIB
TUBE INNER 6" SUIT RIM 6.00X6	100369	156006TU13
TYRE 8" X 4.00	103138	480-400x8 Hiway Part Number: Kend4008JT
TUBE INNER 8" RIGHT ANGLE VALVE	103139	4008TU87
AIR FILTER XT-912	105685	105284
K&N filter oil spray / K&N Filter oil 99 -1131		897 870

Additional consumables are applicable to engine maintenance and heavy maintenance. Refer to the Rotax Maintenance Manual, section 05-00-00 page 10.

A detailed illustrated parts catalogue provided with this aircraft contains reference to the consumables on this aircraft.

00.20.00 Component Overview

Important areas of the Trike base have been identified in this section to aid maintenance personnel.

These photos and list of names are not comprehensive.

Aircraft Structure

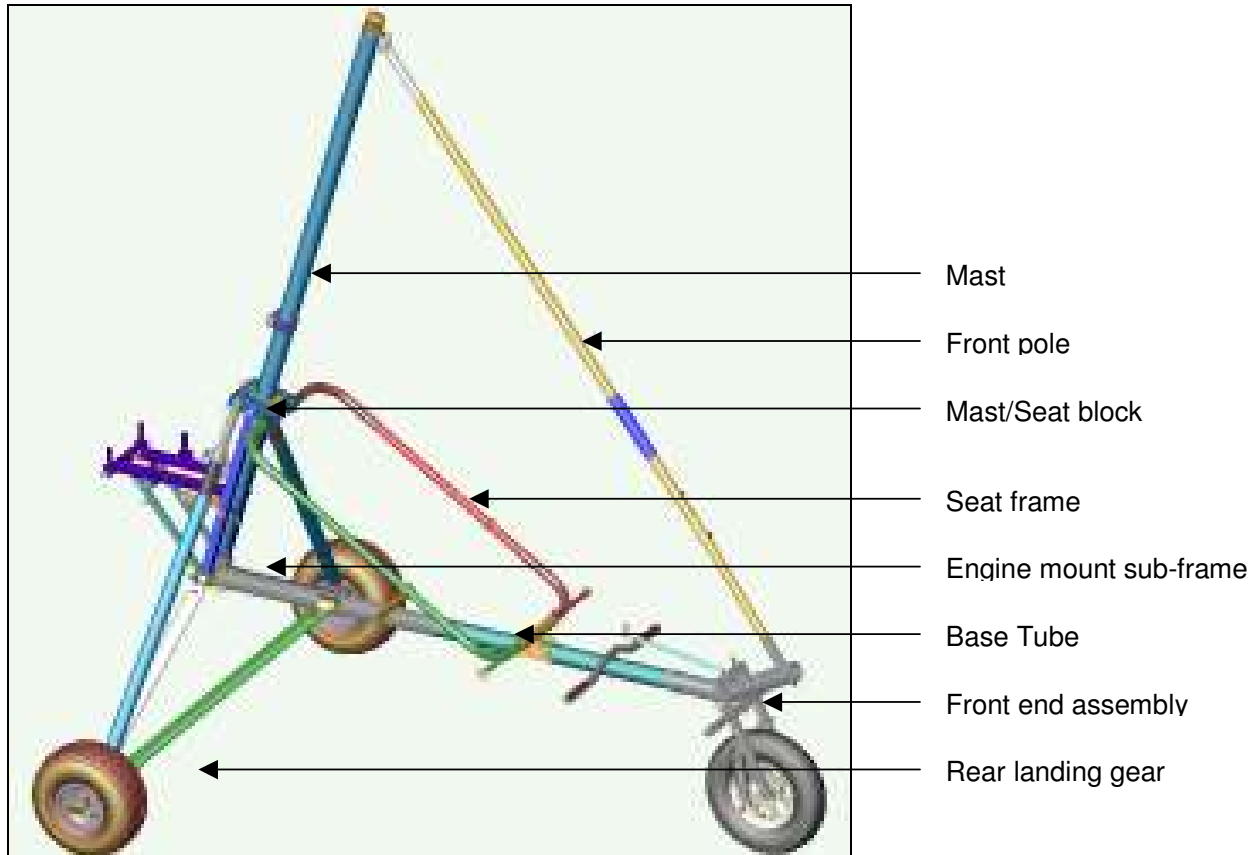

Figure 1 Main structural members

Cockpit



Figure 2 Cockpit

Under-seat bags

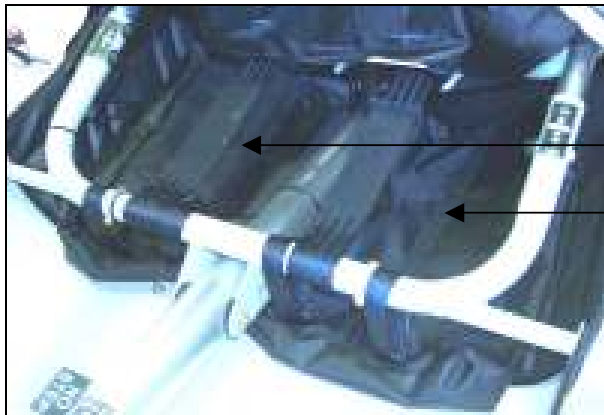

Under-seat bag (rhs)

Under-seat bag (lhs)

Figure 3 Under-seat bags

Mast Block Area



Inertia reel retractors
(mast padding not
shown)

Mast/seat block

Over-centre lever

Seat frame (top corner)

Figure 4 Mast Block Area

Steering and foot levers

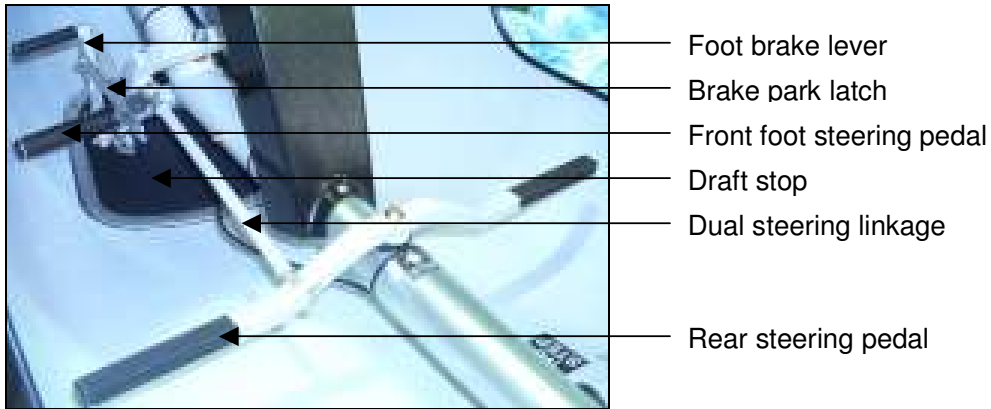

Figure 5 Steering and foot levers

Power Plant

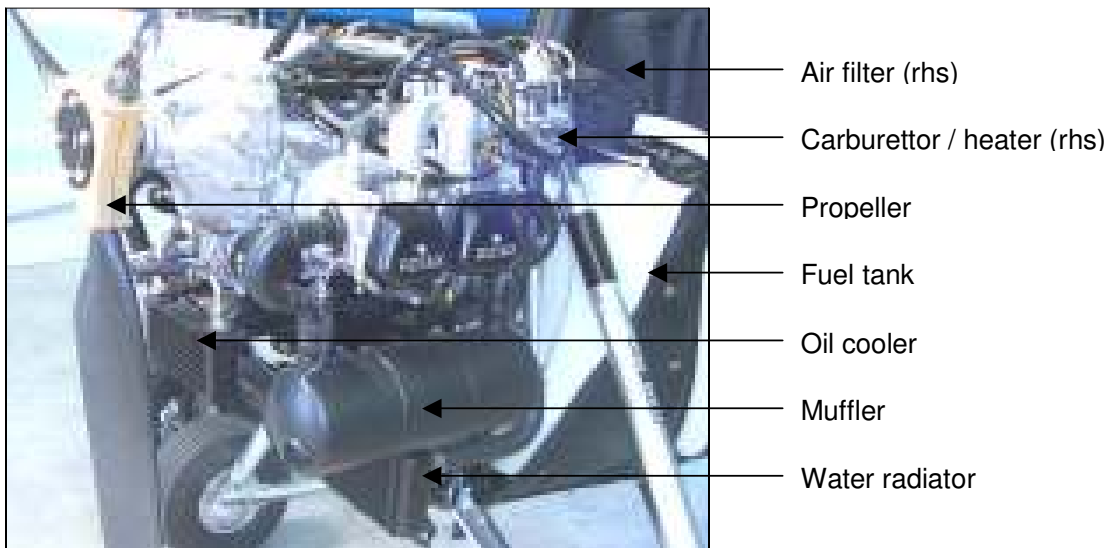

Figure 6 Power plant

4. AIRWORTHINESS LIMITATIONS

4.00.00 *General*

This section sets forth each mandatory replacement time, structural inspection interval, and related structural inspection procedure required for type certification.

4.10.00 *Log of Effective pages – Airworthiness Limitations*

4.20.00 *Airframe Limitations*

Component	Life (hours)	Requirement
Heart Bolt (1 off)	100	Mandatory Replacement. (Drwg 5564)
Front Suspension Pivot Bolts (2 off) Rear Suspension Pivot bolts (4 off)	500	Remove Inspect and replace if necessary. (Drwg 5590&5787)
Masts and Base Tube	953	Check Service Bulletins (See note). Return to service if no SB action required.
Trike Structure, Excluding Masts and Base Tube Structures	8338	Check Service Bulletins (See note). Return to service if no SB action required.

Table 6 Airframe Limitations

The airframe was analysed using FAA fatigue analysis “Fatigue Evaluation Of Wing and Associated Structure on Small Airplanes FAA Report # AFS-120-73-2”, in order to estimate the time life limits for the major components of the airframe, this is detailed in Airborne report 04-144ds. The estimates that have been made do not take into account any extreme loads, which will reduce the fatigue life of the airframe. The fatigue life of these components is dependent upon rigid adherence to maintenance schedules.

The bolts that are listed are known through history of operation to be affected more through mechanical wear than through fatigue, and therefore the time life for these components is less than the calculated values for the airframe.

As the service history of the airframe evolves these time life estimates are expected to be revised, amendments should be checked for regularly.

Note: See Airborne web site for Service Bulletins

5. TIME LIMITS/MAINTENANCE CHECKS

5.00.00 *General*

The time limits and maintenance schedule provided are in addition to any regulation of the governing body where the aircraft is being flown. Some components are subject to overhaul intervals as specified by their manufacturers, Table 5.10.00 gives the overhaul or replacement intervals for these components.

The pilot of the aircraft must ensure that the required maintenance is carried out and documented in the correct manner.

Extreme operating conditions may reduce the time limits for components, unscheduled maintenance is detailed in Section 5.50.00. AirBorne will from time to time amend these maintenance checks as the service history of the aircraft evolves. It is the responsibility of the pilot to ensure compliance with new directives. (Information is available on the website www.Airborne.com.au)

5.10.00 *Time Limits*

The following components are time limited and should be overhauled or replaced as indicated. This table may be updated to include more components in the future as MANDATORY SERVICE BULLETINS are amended.

Component	Life	Requirement
Engine	As specified by Rotax (www.rotax-aircraft-engines.com)	Overhaul or Replace.
Engine Accessories	As Specified by Rotax (www.rotax-aircraft-engines.com)	Overhaul or Replace
Propeller	As Specified by the manufacturer. See section 5.20.20 of Maintenance Manual	Overhaul or Replace
Fuel and Oil Hoses	Five Years or to be replaced during engine overhaul – replacement	Replace
Rocket BRS	As specified by BRS-5 Manual 6 years, return (parachute cannister only) to BRS for repack. 12 years Rocket life. (http://www.brsparachutes.com)	Repack parachute into canister Replace rocket

Table 7 Time Limits of Components

5.20.00 *Scheduled Maintenance Checks*

Airborne Microlights have been designed to permit easy inspection, and operators should have no difficulty in assessing problems or recognising damage if visual checks are carried out correctly. Maintenance checks may require partial disassembly of the aircraft. Inspection should include a thorough visual check of the condition of the component and the attachment point in adequate lighting conditions. Cleaning of the component may be required for proper inspection. Significant scratches, cracks, galling or any other mechanical wear of the component is reason for replacement.

General care should include:

- Washing down the tube work with warm water and a mild detergent followed by rinsing with fresh water.
- Fabric sponged with warm water and a mild detergent and rinsed with fresh water.
- The pod and wheel spats washed and polished using commercially obtainable shampoos and polishes.

- Treat all exposed metal components (including the engine) on the trike base (only) with a dewatering compound such as WD40 or CRC spray. This guards against corrosion and makes cleaning much easier.
- Lubricate the throttle cables regularly using light machine oil.
- The cockpit area should have all litter removed to minimise corrosion and to safeguard the propeller.

Apart from the consequences of heavy landing, or of exceeding flight limitations, the major factors requiring attention are corrosion, fatigue and wear.

There are no known fatigue problems with Airborne Microlights, but excessive loads and vibration can weaken the structure. Regular inspection for hair-line cracks in areas under high stress, such as bolt holes, tube junctions, etc is recommended.

Many components can be replaced with ease, for difficult repairs or if the repair process is not fully understood consult your Airborne Dealer or the Airborne Factory.

The airworthiness of Microlights is only valid provided that all necessary Maintenance, Modification and Service requirements are fulfilled.

These requirements include:

- (a) Maintenance of aircraft as per the Maintenance Schedule in this handbook.
- (b) Modification as detailed in any relevant Service Bulletins.
- (c) Modification to approved details, obtained from Airborne WindSports Pty. Ltd.
- (d) Repairs necessary to replace minor damage, wear or ageing.
- (e) Servicing, replacement and overhaul, inspection and checking in compliance with the Maintenance Schedule.
- (f) Any Airworthiness Directory (AD) issued by CASA or the NAA of the country of registration.

5.20.01 Maintenance Privileges

This manual lists task to be performed on the maintenance schedule. The minimum qualification required to perform that task is prescribed. A simple explanation of maintenance privileges permitted according to LSA category of registration is described in the table below:

	Experimental LSA				Special LSA			
	Sport Pilot	Owner Sport Pilot	LS - I Sport Pilot	LS - M / A&P / part 145 repair	Sport Pilot	Owner Sport Pilot	LS - I Sport Pilot	LS - M / A&P / part 145 repair
Modifications								
Daily Inspections								
Preventative Maintenance								
Repairs, Major Maintenance.								
100 hour inspection								
Annual Inspection								



Authorized to perform.



May perform only if the Repairman Inspector is the owner of the aircraft.



May perform only if the modification is included in the aircrafts Maintenance Manual or if the repairman is authorized to do so by the manufacturer.



May perform if the Repairman Inspector is the owner of the aircraft and not using the aircraft for compensation (training or towing), or

When using the Experimental aircraft for compensation (Training or towing) until January 31 2010, the inspection must be performed by an LS - M / A&P or part 145 repair facility.



Not authorized to perform.

Table 8 Maintenance Privileges

Note that owners and pilots are permitted to perform preventative maintenance tasks as prescribed by FAR document: Part 43, Appendix A Sec. A43.1

Limitations Due to Registered Category

S-LSA

Maintenance on a Special LSA, 100 hourly and annual inspections are to be performed by the holder of a LSA Repairman Maintenance certificate or an appropriately rated A&P mechanic.

Note: owners and pilots are permitted to perform preventative maintenance tasks as prescribed by FAR document: Part 43, Appendix A Sec. A43.1

E-LSA

The owner of an aircraft registered as an Experimental LSA has operations limited to private use and has additional maintenance privileges.

During the transition period, commercial operations may be conducted until 31 January 2010. Where the experimental registered aircraft is used for compensation (training or towing) during the transition period the option c) below does not apply to 100 hourly inspections.

The 100 hourly or annual inspections on an E-LSA are to be performed by:

- a) the holder of a LSA Repairman Maintenance certificate, or
- b) an appropriately rated A&P mechanic, or
- c) the owner when the owner is the holder of a LSA Repairman Inspection certificate.

The pilot of the E-LSA aircraft is responsible to see that the maintenance and inspection has been performed on this aircraft as per the maintenance schedules prescribed in this maintenance manual. The maintenance schedule tasks remain applicable, where there is no minimum level of qualification required to perform maintenance on E-LSA, however a minimum skill level continues to apply to tasks. Only people with an adequate skill level should perform maintenance on this aircraft. A sound understanding of mechanical systems, and good experience with the necessary tools and procedures is required - as the continuing airworthiness of the aircraft relies on the competence of the person performing the maintenance. Assessment and judgement of the condition of each individual component is required, which necessitates a sound understanding of the purpose of each component in the system. If there are any doubts regarding the required and appropriate maintenance then the safety of the aircraft may be jeopardised in continuing with self maintenance. In this situation an Airborne Dealer should be contacted for the correct procedures and or servicing.

All maintenance and repairs must be carried out in accordance with good aeronautical practices.

5.20.02 Description of Task Classification

Preventative Maintenance

The preventative maintenance that is permissible to be performed by pilot certificate holders is defined in FAR document Part 43, Appendix A Sec. A43.1.

Line Maintenance

Includes inspections, servicing of fluids. Tasks where specific instructions are described in the manual that do not require specialized training, for replacement, repair of parts and structure or alterations described in the manual. Includes compliance with service directives that prescribe repairmen as the minimum qualification to perform the task.

Heavy Maintenance

Tasks that require a repairman rating with specialized training or Mechanic with A&P rating, such as major engine work, repair of landing gear assemblies. It also includes alterations to structure where instructions are provided in the manual, such as fitment of an undercarriage kit or a tow kit.

5.20.03 Qualification Descriptions

Certification Required to Perform Light Sport Aircraft Maintenance Tasks

- [O] **Owner**—Items that can be expected to be completed by a responsible owner who holds a pilot certificate but who has not received any specific authorized training.
- [R] **E-LSA Repairman Inspection** - Applicable to E-LSA registration. Repairman Inspection—Items that can be expected to be completed on an ELSA by a responsible owner, who holds an FAA repairman certificate (light sport aircraft), with an inspection rating or equivalent.
- [R] **S-LSA Repairman Maintenance**- Applicable to S-LSA registration. Repairman Maintenance—Items that can be expected to be completed on a S-LSA or E-LSA by a responsible individual, who holds a FAA repairman certificate (light sport aircraft), with a maintenance rating or equivalent.
- [A&P] **Mechanic Certificate with Airframe and or Powerplant Training** - A&P—Items that can be expected to be completed by a responsible individual who holds a mechanic certificate with airframe or powerplant ratings, or both, or equivalent.
- [RS] **Part 145 Repair Station** – Items that can be expected to be completed by a responsible organization that holds a part 145 repair Station approval.
- [TS] **Task Specific** – Items that can be expected to be completed by a responsible individual who holds either a mechanic certificate or a repairman certificate and has received task specific training to perform the task.

When specifying the “task specific” level of certification, the specific training is also specified where it is appropriate.

Note that **dealers may be authorized** by the manufacturer to perform a maintenance or modification task for which they are specifically trained. These tasks are not necessarily included in the Maintenance Manual.

This Maintenance manual is created with the focus to maintain Special Light Sport Aircraft (S-LSA). This category of registration allows the aircraft to be used for hire and reward. Maintenance requirements are given in the maintenance schedule tables. Note that the level of qualification is given for each of the tasks.

Notice that this manual prescribes owner maintenance and repairman maintenance. The minimum applicable repairman ratings for each category of registration are as follows:

E-LSA registered - LSA Repairman Inspection certificate (**LS-I**).

S-LSA registered - LSA Repairman Maintenance certificate (**LS-R**).

In both cases of E-LSA and S-LSA, a person who holds a mechanic certificate with A&P rating, or a part 145-repair station may perform maintenance and inspections on the LSA.

The 100 hourly or annual inspections on a S-LSA are to be performed by the holder of a LSA Repairman Maintenance certificate, an appropriately rated Mechanic with Airframe and Powerplant (A&P) rating, or a part 145 Repair Station.

The holder of a sport pilot certificate may perform preventive maintenance on an aircraft owned or operated by that pilot and issued a special airworthiness certificate in the light-sport category. Items of preventative maintenance that may be performed by an owner are listed in FAR 43 appendix A, Section A43.1 (c)

5.20.04 Rotax Engine Periodic Inspections and Maintenance

Rotax periodic inspections are scheduled according to 50, 100, 200 and 600 hour inspection cycles.

100 h Inspections occur at 100h 300h 500h 700h 900h 1100h.

200 h Inspections occur at 200h 400h 800h 1000h

600 h Inspection occurs at 600h

For convenience the AirBorne XT base periodic maintenance has been brought into line with the above Rotax schedule.

New and overhauled engines require an inspection at 25 hours.

Rotax recommend inspections at 50 hours but state that this is not essential.

For engines operating on AVGAS 50 hour oil changes are required.

Refer to Rotax maintenance manual and Rotax maintenance logbook for the tasks and checklists to be filled when conducting engine maintenance.

5.20.05 Maintenance Task Legend

Your micro light should be maintained in accordance with the following schedules. When registered under LSA, the following schedules are mandatory. The following codes are used in these schedules:

Code

- 1 Oil lubricate, clean and service.
- 2 Check as directed.
- 3 Check for insecurity, cracks, wear legibility and faulty operation.
- 4 Remove, inspect and replace if necessary.
- 5 Recommend replacement or overhaul.
- 6 Mandatory Replacement
- 7 Refer to Rotax maintenance manual and Rotax maintenance logbook.

Certification required to perform Light Sport Aircraft maintenance tasks

- [O] Owner
- [R] E-LSA Repairman Inspection (experimental registered aircraft only)
- [R] S-LSA Repairman Maintenance
- [A&P] Mechanic Certificate Airframe and or Powerplant
- [TS] Task Specific

5.20.06 Log Book

When maintenance is performed always fill out the appropriate check sheet supplied in Appendix A at the rear of this maintenance manual. The aircraft logbook should also be filled out when maintenance has been done.

When Service Bulletins have been complete both the maintenance manual and the log book should be filled out. A copy of the Service Bulletin form should be sent to the factory to be stored with the aircraft QA papers.

A separate maintenance manual is supplied with the wing. The wing maintenance log should be filed out in the wing maintenance manual and aircraft log book.

5.20.10 Power Plant Maintenance Schedule

WARNING

DISCONNECT SPARK PLUG LEADS FOR ALL MAINTENANCE AND INSPECTION PROCEDURES! IF THE ENGINE IS ROTATED AT ANY POINT, IT SHOULD ONLY BE ROTATED IN THE SAME SENSE AS IT RUNS. ROTATING THE ENGINE IN THE OPPOSITE SENSE MAY INTRODUCE AIR INTO THE OIL SUPPLY AND CAUSE DAMAGE TO THE ENGINE.

POWER PLANT MAINTENANCE SCHEDULE	Manual Section Reference	AIRCRAFT OR ITEM HOURS OF OPERATION						
		25	100	200	300	400	500	600
Rotax engine maintenance	72.00.10	2 [R]	2 [R]	2 [R]	2 [R]	2 [R]	2 [R]	2 [R]
Loose bolts / nuts	20.10.10	2 [R]	2 [R]	2 [R]	2 [R]	2 [R]	2 [R]	2 [R]
Engine rubber mounts	71.20.00	2 [R]	2 [R]	2 [R]	2 [R]	2 [R]	2 [R]	2 [R]
Engine platform, mounting plates. Check for cracks		2 [R]	2 [R]	2 [R]	2 [R]	2 [R]	2 [R]	2 [R]
Electrical cable harness	71.50.00	2 [R]	2 [R]	2 [R]	2 [R]	2 [R]	2 [R]	2 [R]
Fuel lines – cracks / tight (See 5.10.00 for time limits)	28.20.00	3 [R]	3 [R]	3 [R]	3 [R]	3 [R]	3 [R]	3 [R]
Fuel tank located and secure / no leaks or cracks	As directed	3 [R]	3 [R]	3 [R]	3 [R]	3 [R]	3 [R]	3 [R]
Fuel filter	28.20.00	2 [R]	2 [R]	2 [R]	2 [R]	2 [R]	2 [R]	2 [R]
Throttle cable (Few drops of light machine oil)	12.20.40	2 [R]	2 [R]	2 [R]	2 [R]	2 [R]	2 [R]	2 [R]
Air filter	12.20.50	2 [R]	2 [R]	2 [R]	2 [R]	2 [R]	2 [R]	2 [R]
Exhaust system	78.00.00	2 [R]	2 [R]	2 [R]	2 [R]	2 [R]	2 [R]	2 [R]
Muffler springs and safety	As directed	3 [R]	3 [R]	3 [R]	3 [R]	3 [R]	3 [R]	3 [R]
Tie wires	20.20.00	3 [R]	3 [R]	3 [R]	3 [R]	3 [R]	3 [R]	3 [R]
Exhaust Gas Temperature Operation	As directed	2 [R]	2 [R]	2 [R]	2 [R]	2 [R]	2 [R]	2 [R]
Cylinder head Temperature Operation	As directed	2 [R]	2 [R]	2 [R]	2 [R]	2 [R]	2 [R]	2 [R]
Engine Tachometer Operation	As directed	2 [R]	2 [R]	2 [R]	2 [R]	2 [R]	2 [R]	2 [R]
Engine Hour Meter Operation	As directed	2 [R]	2 [R]	2 [R]	2 [R]	2 [R]	2 [R]	2 [R]
Engine Oil Temperature Operation	As directed	2 [R]	2 [R]	2 [R]	2 [R]	2 [R]	2 [R]	2 [R]
Propeller bolt torquing	61.10.30	2 [R]	2 [R]	2 [R]	2 [R]	2 [R]	5[R]	2 [R]
Propeller inspection for nicks and abrasions. (see 61.20.00 if repair required)	61.10.10	2 [R]	2 [R]	2 [R]	2 [R]	2 [R]	2 [R]	2 [R]
Propeller removal, disassembly and inspection	Section 61						4 [R]	

Table 9 Power Plant Maintenance Schedule

5.20.20 Trike BaseFrame Maintenance Schedule

TRIKE BASE FRAME MAINTENANCE SCHEDULE	Manual Section Reference	AIRCRAFT OR ITEM HOURS OF OPERATION						
		25	100	200	300	400	500	600
Trike base tube for bend or cracking (see 4.20.00 for time limits)	As directed	3 [R]	3 [R]	3 [R]	3 [R]	3 [R]	3 [R]	3 [R]
Trike mast for bends or cracking (see 4.20.00 for time limits)	As directed	3 [R]	3 [R]	3 [R]	3 [R]	3 [R]	3 [R]	3 [R]
Drag links and rear struts for bends or hole elongation (see 4.20.00 for time limits)	As directed	3 [R]	3 [R]	3 [R]	3 [R]	3 [R]	3 [R]	3 [R]
Mast brace for bend or cracking. Should. Outer brace should slide freely. (see 4.20.00 for time limits)	As directed	3 [R]	3 [R]	3 [R]	3 [R]	3 [R]	3 [R]	3 [R]
Heart bolt (see 4.20.00 for time limits)	As directed	[4]	[6]	[6]	[6]	[6]	[6]	[6]

Table 10 Trike Base frame Maintenance Schedule

Special Instructions

Requirements for TBO

Rotech Research Ltd. is pleased to join with ROTAX in announcing the extension of the T.B.O. (Time Between Overhaul) period for Rotax® 912 and 914 series of piston aviation aircraft engines. The Austrian civil aviation authority (Certificate Authority Austro Control GmbH or ACG) has now granted all of the necessary approvals to increase the time before overhaul (TBO) of the Rotax 912 series from 1200 hours to 1500 hours. The TBO for the popular turbo-charged 914 engine has been increased from 1000 hours to 1200 hours.

These TBO increases are effective immediately and apply to both new engines and existing engines subject to compliance with applicable service bulletins. Please refer to Service Bulletins [SB-912-041](#) / [SB-914-027](#) and [SB-912-041UL](#) / [SB-914-027UL](#) for complete compliance information.

Table 12 <http://www.rotec.com/whatnew.htm>

Time Limit for Rubber Parts

For checking the Engine Mount Rubbers, see “Mounts” Section 71.20.00, for other rubber components related to the engine, see below.

See Rotax Maintenance Manual Section 05-10-00 “Operating Hours Related Checks”

Time Limit for Coolant and Oil

See Rotax Maintenance Manual Section 05-20-00 “Operating Hours Related Checks”

See section 12.10.30 for Coolant details and section 12.10.20 for Oil details.

NOTE

There are Special Instructions when using Avgas, Consult the Rotax Service Information 18 UL 97 D/E.

Special Instructions

Fatigue

The fatigue life calculations given in Section 4. Airworthiness Limitations, give life estimates for the masts, attachments to the wing and Base Tube structure of 953 hours. Service announcements may increase the fatigue life as the service history of the airframe evolves.

50.00 Unscheduled Maintenance Checks

Unscheduled maintenance is required due to abnormal flight loads such as severe turbulence or heavy landings. The pilot will be responsible for identification of these extreme operating conditions and identification of the effected components. Where damage is found further checks should be carried out upon areas that may also be effected.

Thorough checks should also be carried out after transportation of the aircraft, and after extended storage periods.

5.50.10 Inspection after heavy landing

Check shock absorbers for normal operation. Check all attachment points and members of the suspension system. Check all welded lugs for bending or cracking of paint, which may indicate permanent deformation of the area. If any permanent deformation is identified then a more rigorous inspection of the rest of the aircraft is necessary, as permanent deformation indicates that extreme forces have been experienced by the aircraft.

5.50.11 Checking for Deformation

A straight edge may be used on the tubing to ascertain straightness. For checking the overall condition of straightness, a good check is the gap between the front mast and the mast brace.

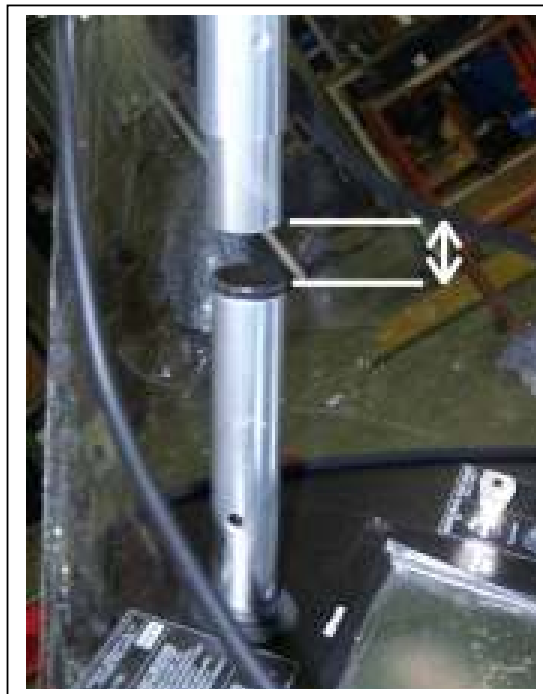

Figure 7 Front Mast to Mast Brace Check

Check Clearance

The dimension measured will have some variability, but should be in the range of 20 to 15mm.

NOTE 1

The dimension should be measured with the wing off, and no pilot in the seat, as this will alter the dimension.

NOTE 2

If the two tubes are closer than the recommended distance or interfere with each other, this indicates significant deformation of the trike base tube, and that the trike has been subjected to significant abnormal loads. The Base Tube should be replaced, and this necessitates a thorough checking of the rest of the aircraft.

Check Alignment

The alignment of the mast brace with the top of the mast can be checked by ensuring that the two tubes slide freely over each other.

NOTE

The sliding should be measured with the wing off, and no pilot in the seat, as this will change the alignment of the tubes.

Attachment Points

Check attachment points for the wing to the base, including the main hang bolt, wheel axles and bearings. The wing should also necessarily be checked after any heavy landing because the forces are transmitted through to the wing structure.

Check the main structure including the base tube, Landing gear attachment points and engine mount. Check all other components attached to the base are in place and properly secured.

Seat Frame

If the airframe has experienced unusual loads then the seat frame should be checked thoroughly. The weight of the pilot during impacts may deform the seat frame.

5.50.20 Inspection after heavy turbulence.

Check all components attached to the base are in place and properly secured, any other items that may have shifted due to in flight movement should also be checked on a regular basis.

Turbulence is more likely to structurally effect the wing of the aircraft rather than the base. The Wing Maintenance manual should be consulted for instructions that pertain to the wing.

6. DIMENSIONS AND AREAS

6.00.00 General

This section gives general dimensions for the base of the aircraft. Imperial and Metric measurements are included. Also included is the overview of the components which make up the Trike Base.

Ground Line The major line through which points are measured from, being the points where the wheels would rest on level ground.

6.10.00 Major Dimensions of the 912

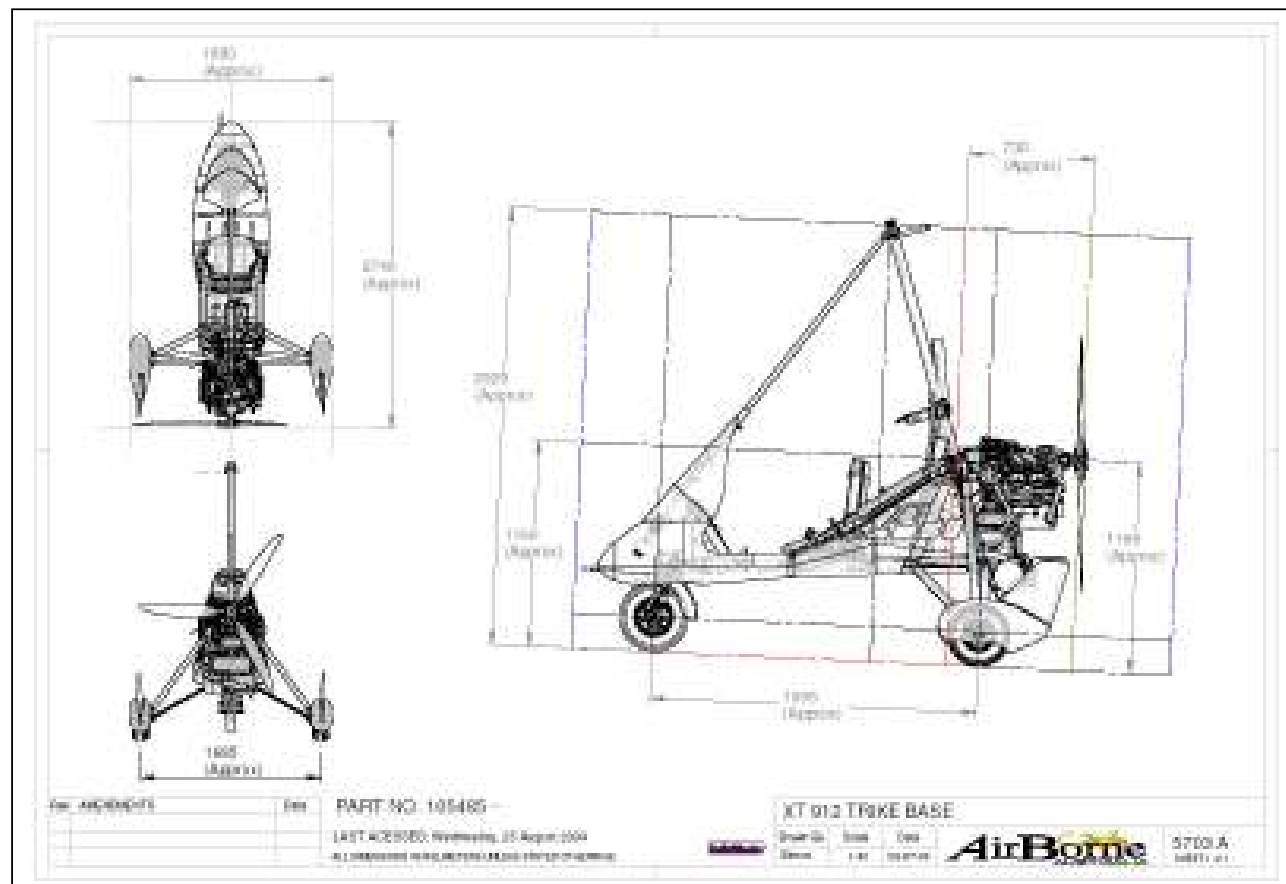

Figure 8 Major Dimensions of the 912

6.20.00 Significant Dimensions and Areas

General

Overall Length (level Attitude) (Nose Cone to Edge of Rotax Propeller Mount)	2740 mm
Overall Width (Edges of Rear Spats)	1880 mm
Height (Without Wing) (Ground to Main Bolt Centre)	2525 mm
Undercarriage Track (Wheel Centres)	1685 mm
Undercarriage Base (Axle to Axle)	1935 mm
Prop Centreline Height (Ground to Centre of Prop)	1165 mm
"Ground Line" to the Engine Mount /Mast Block Assembly intersection	1160 mm
Edge of Rotax Propeller mount to Engine Mount /Mast Block Assembly intersection	0730 mm

NOTE

There may be some differences in these dimensions due to suspension sagging and tyre pressures, as well as the particular way the pod and fittings are mounted.

7. LIFTING AND SHORING

7.00.00 *General*

The Base may be lifted using the main attachment point for the wing or alternatively parts of the base may be lifted for local maintenance such as changing tyres. There are specific areas that have been designated for these purposes.

7.10.00 *Jacking*

Front wheel

The front wheel is lifted by hand using the gap between the front wheel and the fibreglass pod. This is located underneath and at the front. The base's balance point allows easy lifting by hand from this point. Alternatively a strap may be placed around the base tube for long term elevation of the front end.

Rear wheels:

The rear wheel may be lifted from the ground using the jacking point located underneath at the rear of the base tube where the welded tie down point is located. As this point is jacked the rear of the trike will rest on one of the rear wheels and the front wheel allowing each of the rear wheels to be maintained in turn.

CAUTION

NOT TO BE PERFORMED IF THE FUEL TANK IS FULL AS LEAKAGE WILL OCCUR FROM THE FUEL TANK BREATHER TUBES.

Lifting the entire Base

The entire base may be elevated from the ground using the main attachment point, the aircraft should be elevated no more than is necessary.

9. TOWING AND TAXIING

9.00.00 *General*

Moving the trike is a relatively simple operation due to its light weight and manoeuvrability. Moving is easily achievable by one person. If the front of the trike is lifted from the ground care should be taken to prevent the propeller from contacting the ground.

9.10.00 *Towing*

There are two alternatives for “towing” the trike.

Pulling the trike: Moving the base (with or without the wing) is facilitated by lifting the front wheel and walking the base.

Pushing the trike: The trike can be pushed using the base tube, and using a hand on the steering pedals inside the pod for directional control. The brake is available using this method.

9.20.00 *Taxiing*

Taxiing of the trike may be performed with or without the wing attached to the base. Braking and steering are achieved through the front wheel. The trike should never be taxied with excessive speed. Taxiing is a part of the training necessary for flying this aircraft, if an maintenance engineer without trike flying experience is working on the trike they should push the trike and not taxi it, as the control sense may be different to what they are accustomed to.

9.30.00 *Ground Transportation*

The base may be transported overland on a suitable trailer, usually custom built for the purpose. During transport the trike base should be firmly held at both the front and the rear to prevent movement. Tie down straps should be used with a ratchet system so preload can be applied, this allows the tyres to be compressed slightly so as to firmly hold the base in place during transport.

Rear

The rear of the trike base may be secured from the tie down hook, at the centre rear on the engine mount section.



Figure 9 Tie Down Hook Location

Front

The front of the trike should be secured between the front wheel and the fork, on both sides of the axle. Make sure that the tie downs are installed correctly so the brake assembly is not interfered with. Ensure that the park brake is applied.



Figure 10 Front wheel with tie downs

The rear wheels may be tied as well. Route the tie between the drag link and rear suspension member to help prevent damage to the spat.



Figure 11 Tie on Rear Wheel



Figure 12 Trike on Trailer

The above photo shows the trike correctly secured upon a trailer and ready for transport.

10. PARKING AND MOORING

10.00.00 General

This chapter provides information concerning the correct procedures for parking, securing, storage and transport of the aircraft, without packing the trike up. If any maintenance is to be performed on the trike base it is recommended that the wing is removed. For Derigging and storage see sections 9.2 and 9.3 of the pilots handbook.

10.10.00 Parking

Wing Down Park

Park the trike at 90 Deg to the anticipated wind direction and set the brake lock on. The wing tip should then be placed onto the ground on the side of the prevailing wind. The bungee cord and fastener are then used to secure the base bar to the front mast pole. This method of parking the aircraft allows the wind to flow spanwise across and over the wing. For other situations such as strong winds, pack up and hanging, consult the pilots handbook.



Figure 14 Securing of Base Bar With Bungee



Figure 15 Parking of Trike (Upwind Wing Down)

NOTE

The wing tip may be pinned to the ground using a peg such as a tent peg. This will stop the wing from shifting.

Tail To Wind Park

CAUTION

THIS METHOD SHOULD ONLY BE USED WHEN THERE IS LITTLE OR NO WIND. BE AWARE THAT WIND DIRECTION AND SPEED MAY CHANGE RAPIDLY.

Park the trike at 180 Deg to the wind direction (Propeller towards the wind) and set the brake lock on. Attach the base bar to the front mast pole, and secure with the bungee (Same method as above, except at the centre). This method causes the wind to flow over the back of the wing. This method is only recommended for very short periods of time, and in constant (and light) wind conditions.



Figure 16 Parking Trike Tail to the Wind

10.20.00 Mooring

A trike should not be left in the open in fully set up condition for any extended period of time. Consult the pilots handbook for instructions on disassembly, pack up and or hangarage.

Additionally if the trike is to be prepared for transport the pilot handbook section 9.3 should be consulted for the correct preparation and mooring procedures for trailers and transportation.

10.30.00 Long term Hangarage

Long term hangarage will require the supplied air filter covers to be put in place to prevent foreign objects contaminating the air intake area. Full covers for the base are advisable, which are available as after market items from Airborne. The Rotax manual should be consulted for long term storage practices for the engine.

11. REQUIRED PLACARDS

11.00.00 General

The placards that are present on this aircraft are a legal requirement showing safety information, emergency information and identification of the aircraft. The placards must be repaired or replaced if they become illegible or damaged in service. Replacement placards may be purchased from an Airborne dealer or direct.

In the case of the Vne Placard if the ASI has been disassembled the alignment of the ASI and placard should be checked.

11.10.00 Required Placards

The placards on the aircraft are designed to provide information regarding general aircraft limitations and other details for the safe operation of the aircraft.

The placards that are required for operation of this aircraft are available in the Pilot's Operating Handbook, Section 2, "Placards".

12. SERVICING

12.00.00 General

This chapter provides servicing procedures necessary to replenish or service the aircraft and its equipment as required.

The operational integrity of the aircraft systems can be seriously impaired if contaminated fuel, oil, fluids and lubricants are used or if they do not meet the required specifications. Mixtures of various brands and types of materials is undesirable and should be avoided wherever possible even though the use of such mixtures may be technically acceptable. Specified lubricants will meet requirements for extreme hot or cold temperature operations. Use of substitutes or other lubricants may cause malfunction, or excessive wear.

12.10.00 Replenishing

12.10.10 Fuel System Replenishment

Fuel Specification

The XT has a single fuel tank, capacity 70 L.

NOTE

On manufacture the fuel tank has 64 Litre capacity and is known to expand within the first month of use to the specified 70 Litre capacity, take note of this fact when planning flight times.

When the tank is being filled there may be a slight pressure differential between the sides of the tank, causing the fuel cap side to fill slightly faster than the other side. Allow time for the breather valves to equalise the pressure to allow complete filling and, check that both sides are sufficiently full. Fill to the neck of the fuel entrance.

FUEL

Preferred Fuel Type	En228 Premium/Regular. Super grade gasoline, lead free, min RON 90
Optional Fuel Type	AVGAS (see note)

Figure 17 Fuel Specifications

NOTE

Due to higher lead content in AVGAS, the wear of the valve seats and deposits in the combustion chamber will increase. Therefore, use AVGAS only if you encounter problems with vapour lock or if the other fuel types are not available.

Special instructions and service intervals are specified when using Avgas. If Avgas is used the Rotax web site should be referenced for maintenance requirements. See Rotax service information 18-UL-97-D/E, which outlines special instructions regarding the oil system when using AVGAS.

Fuel Sampling/Draining

There is a draincock on the base of the fuel tank at the left hand side, which may be used to check the quality of the fuel, and to drain fuel if necessary, it is especially important to remove any water form the system.

Checking the fuel:

The fuel is checked for water and contaminants by draining a sample of the fuel into a clear glass container. Once a sample has been taken the quality of the fuel can be checked by looking for any water at the bottom of the glass, and checking for any other visual contaminants.

If the fuel has been sitting for an extended period without use it may be advisable to replace it with fresh fuel.

Draining the Fuel

Ensure that a suitable receptacle is found for the fuel that is to be drained, position the trike above the receptacle and depress the draincock. Ensure that there are no ignition sources and that the fuel is disposed of correctly.

12.10.20 Engine Oil System Replenishment

The minimum oil level is 2L, max 3L. This checked and replenished by removing the oil sump lid. Rotax has provided service instructions which detail how to check the oil.

The sump is drained by removing the sump plug. Ensure that the sump plug is correctly replaced and lock wired prior to refilling the engine with oil. Measure the amount to be replaced, refill, check the level, run the engine and recheck. The opportunity should be taken to replace the oil filter any time that the oil is replaced. Use only Rotax oil filters

Consult the Rotax manual and Rotax service instruction 18 UL 97, for the correct type and grade of oil for the ambient operating temperature.

Rotax Oil Replenishment Service Release

Following is a service announcement released by Rotax regarding the Oil system.



SERVICE INSTRUCTION

OIL LEVEL CHECK

FOR ROTAX ENGINE TYPE 912 AND 914 (SERIES)

SI-27-1997 R1

3.1) Instructions

Proceed as follows for

- checking the oil level
- replenishing of oil level

WARNING: Assure both ignition circuits are "Off"(grounded) before cranking the propeller. Anchor the aircraft and ensure the have the is cockpit occupied by a competent person who will be in control of aircraft operation. Risk of burns by hot oil and engine parts exists, use appropriate safety measures! Handle propeller with extreme care and secure engine against unintentional operation!

3.1.1) Oil level check:

a)check for oil leaks:

If leaks are evident, check cause of failure and rectify before flight.

b)check of oil quantity:

- Level aircraft for accurate reading.

Prior to oil level check, remove the oil tank cap and turn the propeller by hand in the direction of normal rotation to transfer all the oil from the engine crankcase to the oil tank.

WARNING: Propeller may not be turned in reverse of the normal direction of rotation.

The process is finished when crankcase air can be heard being forced back to the oil tank. This will be noticed as a gurgle sound, coming from the oil tank with the cap removed, verifying the crankcase is purged of residual oil. The oil level in the oil tank should be between the two marks (max./min.) on the dip-stick, but must never fall below the min. mark.

- Remove the oil dipstick and clean it.
- Return the oil dipstick to the tank.

NOTE: Hold dipstick a few seconds in position to allow an accurate reading.

- Pull out dipstick and check the oil level.

3.1.2) Replenishing of oil quantity:

For normal engine operation maintain the oil level midway between the two marks.

- CAUTION: For longer flights replenish oil to max. mark to warrant more oil reserve.

Do not overfill oil tank, as an excessive oil level over the "max." mark will allow oil to escape via the venting.

Difference between "max." and "min." = 0.45 l (0.95 lig.ptsL If engine is equipped with the genuine ROTAX oil dipstick part no. 956151. Check compliance with Service Bulletin SB-912-040, SB-914-026, "Introduction of a new oil dipstick", current issue to verify your engine has the proper dipstick.

WARNING: Non-compliance with this recommendations could result in engine damage, personal injury or death!

- Restore aircraft to original operating configuration.

3.2) Test run

Conduct test run including ignition and oil/coolant leak checks.

3.3) Summary

These instructions (section 3) have to be conducted in compliance with section 1.5.

Approval of translation to best knowledge and judgment - in any case the original text in the German language and the metric units (SI-system) are authoritative.

APRIL2003
Copyright - ROTAX

SI-27-1997R1
page 3 of 4

- 4) Appendix
the following drawings should provide additional information:

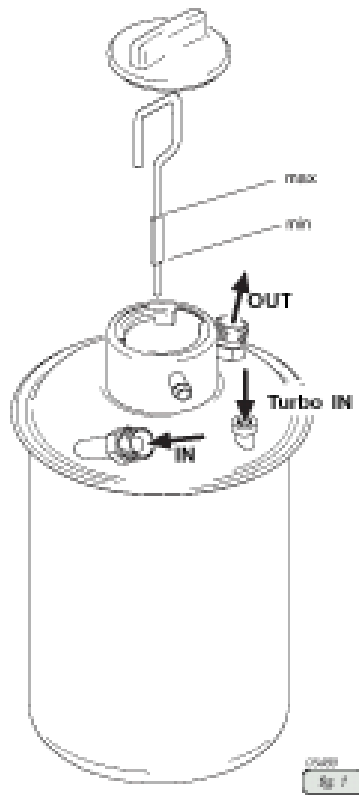

The illustrations in this document show the typical construction. They may not represent full detail or the exact shape of the parts which have the same or similar function. Exploded views are not technical drawings and are for reference only. For specific detail, refer to the current documents of the respective engine type.

APRIL2003
Copyright - ROTAX

SI-27-1997R1
page 4 of 4

Figure 18 Rotax Oil Replenishment Service Release

12.10.30 Coolant Replenishment

Coolant Specification

A MANDATORY Rotax Directive was issued on the 25th of November 2004, which requires a change in the type of coolant that must be used with the Rotax 912 type engine. From the 23rd Feb 2005 the new coolant Evans NPG+ waterless coolant is to be used. The reason for the change is "In some instances conventional coolant (mixture ratio of 50% water and 50% antifreeze) can vaporize or boil before the max permissible cylinder head temperature is reached. Rotax Service Bulletin SB-912-043, pg # 1.

Earlier Airborne trikes have had a silicate free type high quality and long life antifreeze coolant (which is red), Airborne Part Number 106644, installed in the radiator. This coolant must be changed to the newly recommended coolant.

The directive requires that the new coolant be used, and a sticker be placed on the coolant cap, which prohibits the use of water in the coolant system.

Older model XT 912 Trikes with the red coolant may have a 0.9 bar radiator cap. If this is the case a 1.2 bar radiator cap should be installed when the coolant is replaced with the required Evans Coolant.

The coolant should be replaced according to the Rotax maintenance manual, current issue. Please refer to the directive, which is available from the Rotax website: SB-912-043, September 04.

WARNING

WATER OR WATER CONTAINING COOLANT MUST NOT BE ADDED IN ANY CASE TO THE COOLING SYSTEM WITH THE EVANS NPG+ COOLANT.

If the coolant needs to be replaced for any reason it is recommended that the Rotax manual is read, as well as the their service instructions.

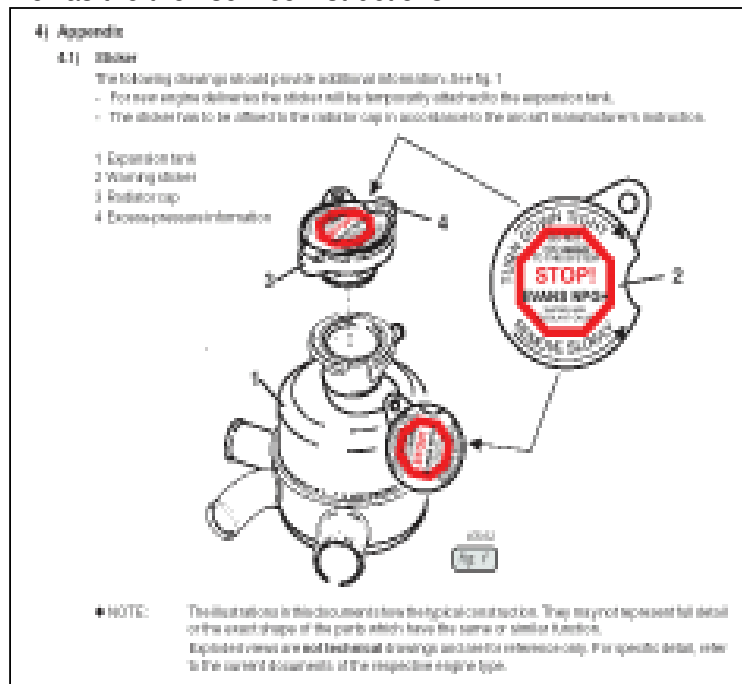

Figure 19 Coolant Warning Sticker instructions. Excerpt from Rotax Service Bulletin SB-912-043, Sept 04.

NOTE

Rotax recommends a two year or 200 hourly replacement interval for coolant.

12.10.40 Tyre Inflation

The recommended tyre inflation pressures are 15 Psi for both the front and rear tyres. When checking the tyre pressures the opportunity should be taken to examine the tyres for wear, cuts, bruises, slippage and other defects.

12.20.00 Scheduled

12.20.10 General

This section provides details necessary to carry out routine scheduled periodic maintenance on the XT airframe and is to be read in conjunction with the XT MAINTENANCE SCHEDULES (Section 5.). Should any conflict occur between information in this section and the XT Maintenance Schedules, the latter will take precedence.

12.20.20 Battery Service

The battery supplied is a Genesis, NP 18-12, 12V, 17.2AH sealed lead acid battery, which requires no maintenance. Earlier model XT 912 bases were supplied with a Century PS Series, PS12180, 12V, 18AH which can be replaced by the Genesis battery if a replacement is needed.

CAUTION

WHEN REPLACING BATTERIES USE ONLY SEALED LEAD ACID OR SEALED GEL TYPE BATTERIES, TO AVOID THE ESCAPE OF CORROSIVES ONTO THE AIRCRAFT STRUCTURE.

The SkyDAT system gives voltage readout. If the voltage drops below 12V then the battery system should be checked for correct charging and battery condition. If the battery is to be replaced a similar sealed lead acid battery may be used, please recycle old batteries.

12.20.30 Airframe Lubrication

This section identifies areas deemed necessary for lubrication and the appropriate frequency of lubrication.

Most of the pivots on the trike are open bush type pivots.

On initial assembly the following joints are assembled with a coating of Petroleum Jelly for ease of disassembly for maintenance or repair: Fork pivot bolt, front and rear wheel axels, front suspension hinge bolt, mast hinge bolt and brake cable.

Each of the wheels on the trike has fully sealed bearings in place that should not require user service as they have been lubricated and sealed by the manufacturer.

If no lubrication interval is specified for a component, lubricate as required and when assembled or installed.

General Lubrication Notes:

- All lubrication points should be serviced when overhauled.
- Dry Lubricant should be used on the brake latch.
- Throttle cable and choke cables should be lubricated with a light machine oil every 100 hrs

12.20.40 Cable Lubrication

The throttle and choke cables have been lubricated with light machine oil on initial assembly.

The Brake Cable is lubricated with Vaseline on initial assembly.

12.20.50 Air Filter

Dust and dirt that make their way into the engine are probably the greatest cause of premature engine wear. The value of maintaining the air filter in good condition cannot be overstressed. The condition of the air filter should be checked as per the maintenance schedule, and if extreme operating conditions are experienced they should be checked more frequently. Also check the condition of the air filter after any extended hangarage.

12.20.60 Air Filter Service Instructions

These service instructions apply to K&N air filters.

- (1) Tap the element to dislodge any large embedded dirt, then gently brush with a soft bristle brush.
- (2) Spray K&N air filter cleaner liberally onto the entire element and let soak for 10 minutes.

CAUTION

DO NOT USE PETROL, STEAM, DETERGENTS OR OTHER CLEANING SOLUTIONS OR SOLVENTS. ANY OF THESE PRODUCTS CAN CAUSE HARM TO THE COTTON FILTER OR SHRINKAGE OR HARDENING OF THE RUBBER END CAPS.

- (3) Rinse off the element with low-pressure water. Tap water is OK. Always flush from the clean side to the dirty side. This removes the dirt and does not drive it into the filter.
- (4) Shake off all excess water and let the element dry naturally.

CAUTION

DO NOT USE COMPRESSED AIR, AN OPEN FLAME OR OTHER HEAT SOURCES. COMPRESSED AIR WILL CREATE HOLES IN THE ELEMENT WHILE EXCESS HEAT WILL CAUSE THE COTTON FILTER TO SHRINK.

Apply K&N air filter oil to the filter after it is dry. Apply the oil along the top and bottom of each pleat. Wait 20 minutes and re-oil any white spots still showing.

12.20.70 Cleaning

Windshield

The windshield is made from a polycarbonate material and therefore a certain amount of care is required to keep it clean and in good condition. The following procedure is recommended.

1. Flush with clean water to remove excess dirt, bugs and other loose particles.
2. Wash with mild detergent and warm water. Use a soft cloth or sponge, do not rub excessively
3. Rinse thoroughly, then dry with a clean moist chamois. Do not use volatile solvents such as gasoline, alcohol, benzine or most commercial window cleaning sprays, as they will adversely affect the plastic.

Painted Surfaces

The painted exterior surfaces of the aircraft can be washed using a mild detergent and water, alternatively an automotive liquid detergent may be used.

Engine

An engine and accessories wash down should be performed regularly to remove any oil, grease, and other residue. Periodic cleaning allows proper inspection of the engine components and can be an aid to discovering defects during inspection as well as reducing the potential for an engine fire during aircraft operation.

The engine may be washed down using a suitable solvent, then dried **thoroughly**.

During cleaning, the Air intakes, BRS parachute, and the electronics should be protected with a thin plastic film, as shown in this photograph.



Figure 20 Areas to be protected during cleaning

WARNING

DO NOT USE PETROL OR ANY OTHER HIGHLY FLAMMABLE SUBSTANCES FOR WASH DOWN. DO NOT ATTEMPT TO WASH AN ENGINE THAT IS STILL HOT OR RUNNING. ALLOW THE ENGINE TO COOL FULLY BEFORE CLEANING. PERFORM ALL CLEANING OPERATIONS IN A WELL VENTILATED WORK AREA, PREFERABLY OUTSIDE, AND ENSURE THAT PERSONAL PROTECTIVE CLOTHING IS WORN AND THAT FIRE FIGHTING SAFETY EQUIPMENT IS READILY AVAILABLE.

CAUTION

PARTICULAR CARE SHOULD BE GIVEN TO ELECTRICAL EQUIPMENT BEFORE CLEANING. SOLVENT SHOULD NOT BE ALLOWED TO ENTER ANY OF THE ELECTRICAL EQUIPMENT. ELECTRICAL COMPONENTS SHOULD BE PROTECTED BEFORE SATURATING THE ENGINE WITH SOLVENT. ANY OIL, FUEL, AND AIR OPENINGS ON THE ENGINE AND ACCESSORIES SHOULD BE COVERED BEFORE WASHING THE ENGINE WITH SOLVENT. CAUSTIC CLEANING SOLUTIONS SHOULD BE USED CAUTIOUSLY AND SHOULD BE NEUTRALISED AFTER USE.

Propeller

The propeller should be cleaned occasionally with water and a mild detergent to remove dirt, grass and bug stains. The opportunity should be taken to visually check the condition of the propeller during cleaning.

Upholstery and Interior

The Pod area should be vacuumed out to remove all loose Dirt/Gravel etc. All vinyl surfaces can be wiped with a product such as Armourall surface protectant. The seat is a structural part of the airframe and care should be taken to avoid any substance that will degrade the webbing material, vacuuming is recommended for the upholstery.

12.20.80 Fibreglass Repair

WARNING

THE PROPELLER IS NOT FIBREGLASS AND SEPARATE INSTRUCTIONS IN SECTION 61 HAVE BEEN INCLUDED FOR THE REPAIR OF THE PROPELLER. DO NOT USE FIBREGLASS OR POLYESTER RESIN ON THE PROPELLER AS IT IS STRUCTURALLY INFERIOR FOR THE LOADS ON THE PROPELLER AND THE RESINS MAY BE INCOMPATIBLE, AND THEREFORE UNSAFE.

The fibreglass that makes up the pod and spat structures of the trike is made from polyester resin and chopped strand fibreglass. The fibreglass components may be repaired using polyester resin and fibreglass mat, or chopped strand mat which is probably the preferable choice for easy thickness build up. Make sure that the surfaces have been correctly prepared for adhesion of the repair. Full repair instructions for the fibreglass components is beyond the scope of this manual, there are many good texts available for practical composite repairs.

Some guidelines for repairs:

- Repair thickness should at least equal original material thickness in all cases, preferably half on the inside and half on the outside.
- For attachment points the repair thickness should be increased by half again.
- Repairs should overlap damage by at least 35mm on all sides.
- Repairs are prohibited within a radius of 150mm of the pitot tube.
- Repairs in the vicinity of the Pitot must maintain the original profile or the repair will adversely effect airworthiness.

12.20.90 Paint Repair

Colour matched Touch up paint is available through the Airborne Dealer network.

Frame components are powdercoated. And the fibreglass fairings are 2 pack acrylic eurothane enamel.

Repair methods on small damaged areas are the same for both paint systems.

Repair of small chips may be performed using brush touch of acrylic paint.

Repair of larger areas may be performed by:

Scuffing to provide key.

Apply epoxy based etch primer, rub back.

Apply acrylic lacquer final coat.

Application may be by spray or brush depending on the desired finish. Paint repairs may be referred to your local automotive smash repair shop.

20. STANDARD PRACTICES - AIRFRAME

20.00.00 General

This chapter provides standard torque values and safetying procedures that are to be used in all areas of the aircraft unless otherwise specified. The use of these standard values and procedures will ensure the security of installation and prevent overstressing of components.

20.10.00 Torquing Procedures

Correct Torquing of fasteners is critical, if a bolt or fastener is too loose it may cause unnecessary movement resulting in wear or fatigue, while over tightening may cause tensile failure of the bolt, or crushing of components. Torques should be determined using an accurate torque wrench during installation. The torque required after the nut is fully on the shaft, but not against the mating surface should be added to the final torque value.

Special Torquing Procedures

Seat Mast Block Sub Assembly

The Seat Mast Block has special torquing procedures that need to be followed. Drawing 5658 is supplied showing the required Torque values, as well as the Loctite required.

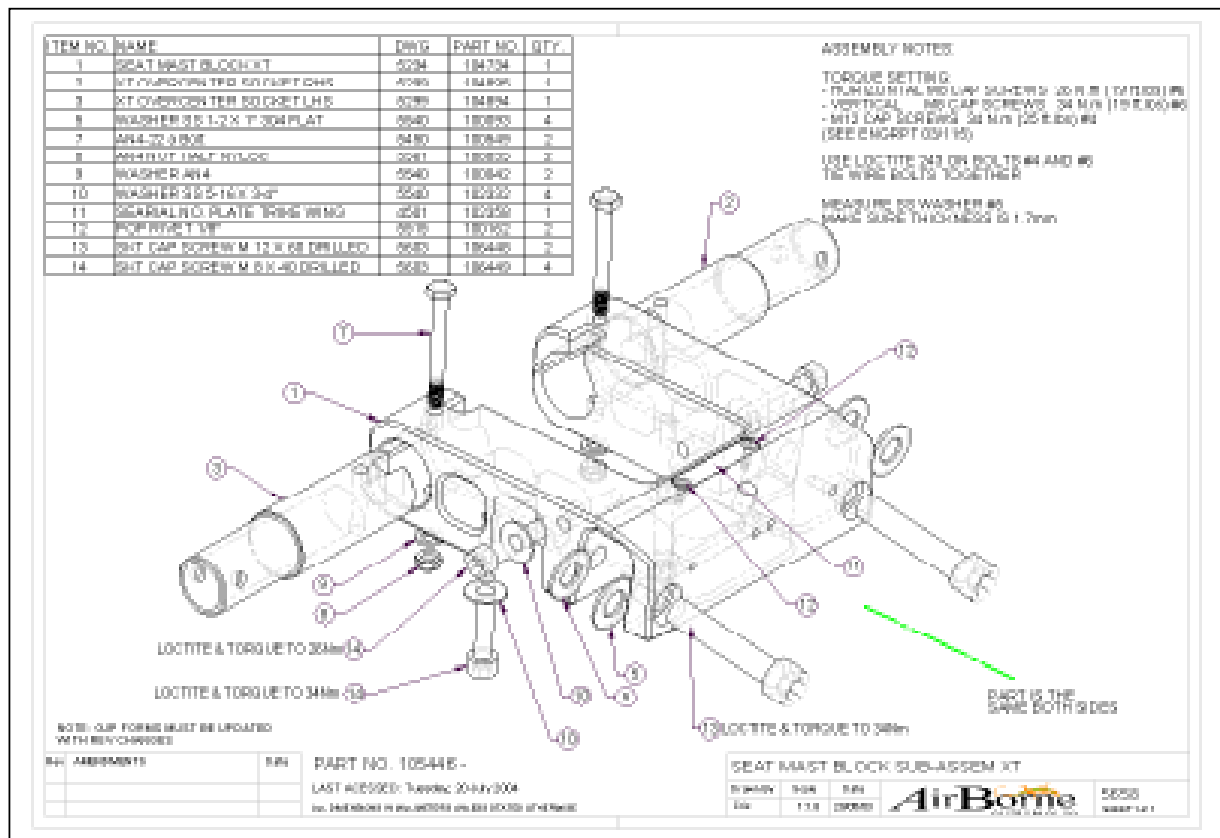

Figure 21 Seat Mast Block Sub Assembly

Front wheel

The front wheel axle bolts should be torqued to 27Nm on each side, before the locking bolts are tightened.

Rear Wheels

The rear wheels need to be set up in a special way because of the spat brackets.

Procedure after Shipping:

The inside two nuts and bolts are pre set at the factory. The outer bolt, and bracket should tighten sufficiently, and at the same time be near to parallel to the ground, for the correct spat installation. Do not over tighten and make sure that the wheel is fully seated on the inside. If not then the full procedure should be followed.

Full Procedure:

1. With the lock bolt and the inside Nyloc nut loose, tighten the outside bolt, with incorporated spat bracket, until it is sufficiently far onto the bolt, and is resting at approximately 10 Deg to the ground, higher end at the rear. Make sure that the split washer is included.
2. Tighten the inside bolt, be careful not to over tighten to protect the bearings. Make sure that there is at least one full thread pitch showing.
3. Tighten the locking bolt. Make sure that there is at least one full thread pitch showing.

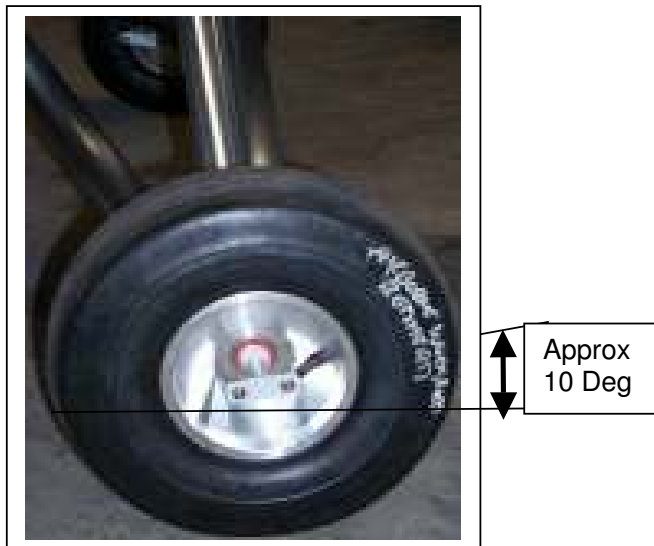

Figure 22 Outside Nut with spat bracket



Figure 23 Inside Nut and Inner Spat Bracket

NOTE

The Inner Spat Bracket is intentionally bent inwards at each end.

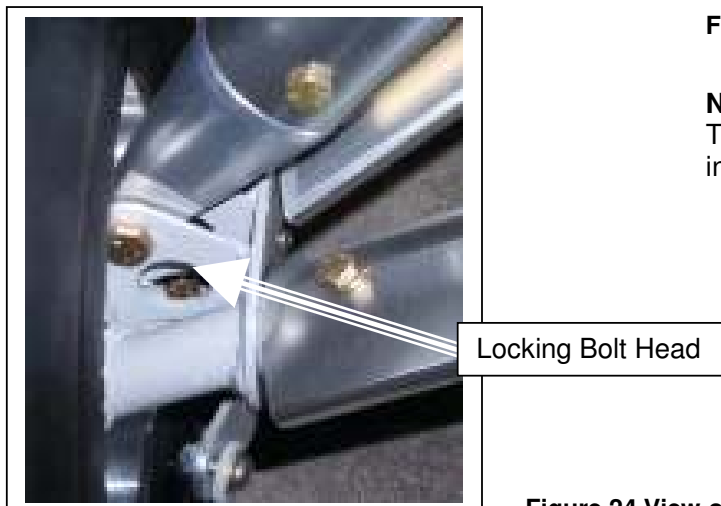

Figure 24 View of Locking Bolt head

Spat Installation

The spats are made from a fibreglass polyester composite material, for this reason care should be taken to ensure they are not damaged during their installation. They are held by Nyloc nuts, for this reason they do not need to be tightened to the point of crushing the composite (fibreglass).

General Torquing Procedures

General Torquing Exceptions

1. Joints with Hinges or Bearings, where the specified torque value would prevent free operation.
2. Bolts, nuts and screws that attach plastic or fibreglass or aluminium tube components, where the softer material would be damaged by specified torques.
3. Engine bolts are to be torqued to the engine manufacturers specifications, and may need to be sequenced.

Applicable to the following BOLTS and SCREWS: AN3 thru AN20 AN42 thru AN49 AN73 thru AN81 AN173 thru AN186 NAS1303 thru NAS1320 NAS6600 thru NAS6608 AN509 AN525 MS20073 MS20074 MS24694 MS27039 NAS1300 NAS6605								
Applicable to the following NUTS: Tension Nuts - AN310 AN315 AN363 AN365 MS20365 MS20500 MS21042 MS21045 NAS679 NAS1021 Shear Nuts - AN316 AN320 AN364								
TORQUE LIMITS RECOMMENDED FOR INSTALLATION (BOLTS LOADED PRIMARILY IN SHEAR)								
FINE THREAD SERIES								
Tension Type Nuts					Shear Type Nuts			
	Nm		in lbs		Nm		in lbs	
Thread	Min	Max	Min	Max	Min	Max	Min	Max
8-36	1.4	1.7	12	15	0.8	1	7	9
10-32	2.3	2.8	20	25	1.4	1.7	12	15
1/4-28	5.6	7.9	50	70	3.4	4.5	30	40
5/16-24	11.3	15.8	100	140	6.8	9.6	60	85
3/8-24	18.1	21.5	160	190	10.7	12.4	95	110
7/16-20	50.8	56.5	450	500	30.5	33.9	270	300
1/2-20	54.2	78	480	690	32.8	46.3	290	410
9/16-18	90.4	113	800	1000	54.2	67.8	480	600
5/8-18	124.3	146.9	1100	1300	74.6	88.1	660	780
3/4-16	259.9	282.5	2300	2500	146.9	169.5	1300	1500
COARSE THREAD SERIES								
Tension Type Nuts					Shear Type Nuts			
	Nm		in lbs		Nm		in lbs	
Thread	Min	Max	Min	Max	Min	Max	Min	Max
8-32	1.4	1.7	12	15	0.8	1	7	9
10-24	2.3	2.8	20	25	1.4	1.7	12	15
1/4-20	4.5	5.6	40	50	2.8	3.4	25	30
5/16-18	9	10.2	80	90	5.4	6.2	48	55
3/8-16	18.14	20.9	160	185	10.7	12.4	95	110
7/16-14	26.6	28.8	235	255	15.8	17.5	140	155
1/2-13	45.2	54.2	400	480	27.1	32.8	240	290

Table 11 Torque Table

NOTE

Castellated nuts requiring cotter pins should be tightened initially to the lower value. Torque can then be increased up to the maximum limit in order to install the cotter pin. A thick or thin washer may be added under the nut as required in order to maintain within tolerances.

20-20-00 Safetying Procedures

All bolts and nuts, except the self locking type, should be safetyed after installation. This prevents them from loosening in flight due to vibration.

Lock Wiring

Lock wiring is the most positive and satisfactory method of safetying nuts, bolt heads and turnbuckle barrels that cannot be safetyed by any other practical means. Two or more units are wired together in such a manner that any tendency of one to loosen is counteracted by the tightening of the wire. This is especially important for trikes in flight, as the propeller is located downstream of the flight direction, and any component that becomes loose will tend to be pushed into the propeller and engine.

Following is an excerpt from a manufacturing Quality Control form giving all of the locations of tie wires, which need to be checked regularly. (The engine scheduled maintenance table details the time interval for checks.)

TIE WIRE INSTALLED
Engine Mount Angle Cap Screws LHS
Engine Mount Angle Cap Screws RHS
Oil Pressure Relief Valve Bolt Head
Oil Tank Side Clamp
Oil Tank Drain Plug
Oil Tank Top Clamp
Engine Sump Banjo Bolt
Exhaust Springs
Compression Strut Assem to Seat-Mast Block LHS
Compression Strut Assem to Seat-Mast Block RHS
Seat Mast Block to Engine Mount LHS 2 off
Seat Mast Block to Engine Mount RHS 2 off
Engine Mount Tie Rod to Seat Block
Propeller Bolts x 6

Table 12 Excerpt from GJP 141, Complete List of Tie Wire locations



Figure 25 Tie Wires on Propeller



Figure 26 Rear Wheels Self Locking Nuts

The two photographs above give examples of safetying devices. There is special instructions in the propeller section for tie wiring.

WARNING

IT IS UNSAFE TO OPERATE THE AIRCRAFT WITHOUT THE SPATS INSTALLED. THIS IS BECAUSE THE SPAT ATTACHMENT TO THE WHEEL NUT STOPS IT FROM ROTATING AND BECOMING LOOSE DURING OPERATION. THE NUT ON THE SHAFT HAS A SPRING WASHER BUT NO NYLOC OR OTHER SAFETYING DEVICE, AS IT IS UNNECESSARY WHEN ATTACHED TO THE SPAT.



Figure 27 Muffler Safety Wire and Springs

The Muffler components are attached to each other via a spring which is in turn safetied with wiring.

Soft Side Safetying

Each of the soft side securing bolts are loctited into position. This is necessary because if they were to come loose they may impact the propeller.

Mast Top

The wing (wing heart bolt not shown), wing safety strap and front pole are locked in place with wing nuts and safety clips as shown below.



Figure 28 Mast Top Safetying

Self Locking Nuts

Self locking nuts are used at joints that subject neither the nut or the bolt to rotation in service. Self locking nuts may be reused but not if they can be run on the thread by hand without using tools. After a self locking nut has been tightened at least one full thread pitch of the male thread must protrude through the nut locking feature.

20-30-00 Control Cables And Terminals

Control cables on the trike base include throttle cables, Choke cables and brake cables. These need to be checked regularly for excessive friction and wear. The cables may be lubricated with light oil if necessary. Wear is most likely to occur at the ends of the cables at the attachment points.

20-40-00 Rust Proofing

During manufacture all of the steel components have been treated with rust proofing agent inside the tubing, The exterior is protected with powder coat paint.

Where steel components are removed or inspected the opportunity should be taken to inspect the interior, use a high quality rust proofing agent and apply after inspection has been completed. If the aircraft is operated in coastal areas and or has had exposure to corrosive environments rust proofing is especially necessary.

23. COMMUNICATIONS

23.00.00 General

All maintenance and servicing of communications avionics equipment fitted to the XT 912 should be carried out by approved agents of the avionics manufacturer.

The intercom and radio system schematic are shown in the electrical schematic (section 7.13) in the Pilots handbook.

23.10.00 Fuses

The fuses for the electrical equipment are located in two positions.

1. The Lynx intercom system has a 1.5A fuse screwed into the side of the box where the headsets and push to talk cables are plugged in.
2. The power supply cables for the radio are protected at the rear of the aircraft with inline fuses which terminate at the right hand side of the mast block. A 5A fuse is to be used for the radio and intercom power supply. The fuse holder is marked with the correct current rating for the fuse.
3. The battery charging circuit is protected with a 20A fuse, which also terminates at the right hand side of the mast block. The fuse holder is marked with the correct current rating for the fuse.

24. ELECTRICAL POWER

24.00.00 *General*

The 912 Trike base has a 12V electrical system essentially comprising of a 12V battery, the Rotax alternator and accessories. A detailed description and schematic are available in the pilots handbook, section 7.13. The Rotax manual should be consulted for the maintenance of the engines electrical system (Rotax 912 UL).

24.10.00 *Maintenance*

The maintenance of the electrical system should include periodic inspection of the wiring loom for chafing and other damage through it's entire length. Pay special attention to the areas that are subject to possible wear points such as sharp corners or proximity to parts which move. It should be noted that the electrical wires may be subject to wear through vibration in flight.

Wiring that is damaged should be replaced and if any wear points are identified then a product such as spiral wrap should be used to cover the area. The advantage with the use of spiral wrap is that it allows inspection of the wires even after it is installed.

25. EQUIPMENT/FURNISHINGS

25.00.00 General

Section 5.20.00 contains general care instructions, which should be referred to for washing and treating surfaces.

25.10.00 Flight compartments

The structural integrity of the webbing on this aircraft is critical for safe operation. All of the webbing should be inspected for signs of wear, fraying, cuts, or other mechanical damages, as well as any significant UV damage that may have occurred.

NOTE

It is preferable to store the aircraft away from direct sunlight.

25.10.10 Seats

The seat structure consists of a seat frame assembly which is attached to the mast block, and through two steel welded lugs onto the base tube. The Seats themselves structurally consist of webbing which is attached to the seat frame, The padding and other areas of the seats are non structural components

25.10.20 Occupant Restraint Systems

Both the pilot and passenger seats are fitted with both lap and shoulder belts. Both of these should be periodically checked for wear and correct operation. In particular the stitching, webbing, and all attachments. Any worn or damaged belts or fittings should be replaced, this includes belts that have been subject to extreme loads during a heavy landing. It should be noted that in order to inspect the seatbelts they need to be pulled out as far as possible from their reels.

Check the shoulder harness inertia reel for corrosion, moisture and debris. Check that the belt retracts readily and locks when pulled suddenly. Check the lap belt connector for proper operation, engagement and release.

Airborne should be contacted for spare parts.

25.10.30 Safety webbing

The top of the mast has safety webbing for the unlikely event of failure of the main mast bolt.

25.10.40 Operation of Seatbelts

The Pilot's Operating Handbook Should be consulted for correct usage instructions for the seat belts.

27. FLIGHT CONTROLS

27.00.00 General

For information on the flight controls system refer to the relevant wing maintenance manual.

27.10.00 Engine Controls

The engine is controlled through cable actuated throttle levers which may be actuated by pilots in the front or rear of the aircraft. The foot throttle is only available to the front pilot, while the hand throttle is able to be actuated by both.

The cables and levers should be checked for free operation, and ensure that there are no kinks in the cables. Light machine oil may be used to lubricate the cables.

NOTE

If any sign of wear or damage is evident then the cable assembly should be replaced.

28. FUEL SYSTEM

28.00.00 General Description

This section pertains to the components which store and deliver fuel to the engine. The XT 912 Fuel system is simple and easily visually inspected. Fuel rate sensing transmitting and indicating are covered in chapter 73.

Features:

Capacity 70 Litres.

Useable fuel 67 Litres.

Fuel drain tap.

Breather system.

Safety fuel tap.

Fuel Filter.

The Rotax engine contains the fuel pump. Consult the Rotax manual for instructions.

Sight gauge for remaining fuel.

Electric Flow Meter for electronic fuel usage information.

(Usage information provided by the digital flight display.)

The following schematic should be used to ensure the correct sequence of installation if the fuel lines are being repaired or replaced.

CAUTION

THE FLOW METER AND THE FUEL FILTER ARE DIRECTIONAL, THEY MUST BE INSTALLED SO THAT THE FUEL FLOWS IN THE CORRECT DIRECTION.

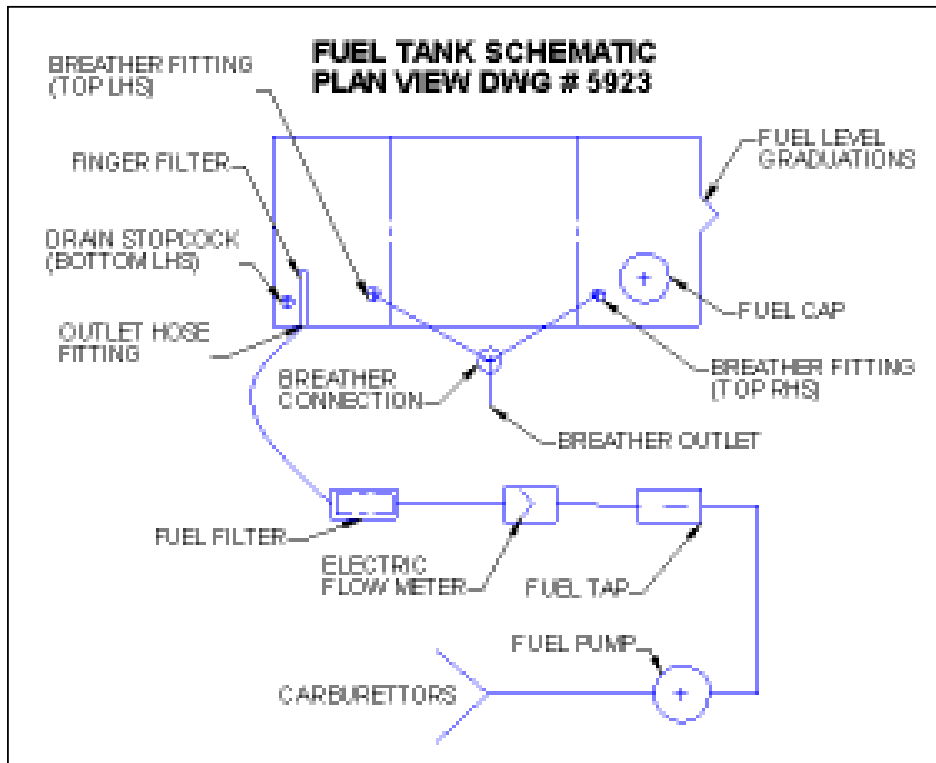

Table 13 Fuel Tank Schematic

28.00.10 General Precautions and Procedures

WARNING

DO NOT PERFORM ANY MAINTENANCE ON THE FUEL SYSTEM IN CONJUNCTION WITH MAINTENANCE ON THE ELECTRICAL SYSTEM. NO SMOKING OR IGNITION SOURCES WITHIN 50FT OR 15M FROM THE BASE.

FUEL WILL DEGRADE WING MATERIAL AND UPHOLSTERY IN THE TRIKE, CARE SHOULD BE TAKEN TO PREVENT ANY SPILLAGES.

28.10.00 Fuel Storage

Tank

The storage system consists of a single fuel tank located underneath to the sides and to the rear of the passengers seat. Nb. The actual fuel tank has no provision for repair, if the fuel tank is damaged in any way that makes it unsafe it should be replaced, contact Airborne.

Fuel Cap

The fuel cap has a one way valve attached which allows air to enter the tank, while preventing fuel escaping.

Fittings

The tank has a draincock, two ventilation fittings and the main supply fitting attached to it.

Sealant

The fittings are attached to the fittings using Loctite 567 Thread Sealant. If for any reason the fittings have to be removed, then the same sealant should be used to ensure compatibility and correct sealing. The Loctite number for ordering is 56747, and the instruction supplied with the product should be followed.

Testing the Fuel Tank

The fuel tank has been pressure tested at the factory during manufacture, if any suspected leaks are to be tested the tank should be tested to 10.35 kPa (1.50 psi). All fuel should be removed, and all fittings disconnected prior to this test being performed, so that other components of the system are not effected by the test. Do not inflate the tank more than the recommended amount for the pressure test as this may damage the tank.

28.10.10 Venting

The tank is protected from negative pressures by both the breather valves and the Fuel Cap, which allows air in if the pressure is lower inside the tank than out. The tank is protected from positive pressure build up by the breather tubes that are present at the top of both the right and left hand sides of the tank, at the top.

28.10.20 Draining and Checking

There is a draincock on the base of the fuel tank at the left hand side, which may be used to check the quality of the fuel, and to drain fuel if necessary. See section 12.10.10.

28.20.00 Distribution

The fuel supply is taken from the base of the left hand side, and is protected from large contaminants by a finger filter. The fuel is drawn by the Rotax fuel pump system. The Rotax manual should be consulted for maintenance and operating procedures for the fuel pump system.

CAUTION

ELIMINATE IGNITION SOURCES AND BE AWARE OF THE FUMES THAT EMANATE FROM THE FUEL TANK.

Breather Lines

The breather lines are attached to the breather fittings without adhesives, the interference fit is used to secure them. The breather lines are made from 6mm ID PVC tubing, which may be replaced if necessary.

Finger Filter

A horizontal finger filter is installed into the tank where the main fuel line is attached. The length of the finger filter is necessary so that a minimum amount of fuel is left in the tank. The condition of the finger filter may be visually inspected through the fuel cap hole with an empty tank, this may be assisted by jacking the back of the trike, and tilting it to the pilots right (See Jacking – Section 7.10.00).

Cleaning of the main tank Finger Filter

NOTE

The removal of the finger filter has been simplified with a non structural change to the engine mount. Check the serial number of the Trike which you are performing maintenance on and follow the relevant instructions.

Serial Numbers from 61 onwards should use the following instructions:

1. Remove the fuel from the tank.
2. Turn the Main Fuel tap to the off position.
3. Remove the fuel hose from the 90 Deg brass fitting that attaches to the finger filter.
4. Unscrew the brass fitting from the aluminium finger filter.
5. Unscrew the finger filter from the tank and remove.
6. Remove any accumulated debris from the filter, and flush the bottom of the tank thoroughly, you may need to lift the front of the base for this.
7. Check the condition of the filter, replace if damaged.
7. Installation is the reverse of removal. Check hose and fittings, use Loctite 567 on the connections between the filter and brass fitting, and the two brass fittings. Do not allow excess to enter the fuel line.

Serial Numbers from 0 to 61 should use the following instructions:

1. Remove the fuel from the tank.
2. Turn the Main Fuel tap to the off position.
3. Remove the fuel hose from the 90 Deg brass fitting that attaches to the finger filter.
4. Unscrew the brass fitting from the aluminium finger filter.
5. Remove the front two locating bolts on the fuel tank. (Underneath at the front)
6. Remove the lower rear centre fuel tank bolt. Removing these bolts temporarily allows the fuel tank to move enough so that the finger filter may get past the engine mount.
7. Unscrew the finger filter from the tank, move the tank slightly to allow removal.
8. Remove any accumulated debris from the filter, and flush the bottom of the tank thoroughly, you may need to lift the front of the base for this.
9. Check the condition of the filter, replace if damaged.
10. Installation is the reverse of removal. Check hose and fittings, use Loctite 567 on the connections between the filter and brass fitting, and the two brass fittings. Do not allow excess

to enter the fuel line. Use Loctite 243 on the three fuel tank screws, ensure that the split washer is also present on each.



Figure 29 Finger Filter, as installed, as well as the unit prior installation.

NOTE

In the photo the components:

- Filter
- O Ring
- 90 Deg Fitting
- Fuel Hose and Clamp

Each joint must be ensured to be free from leakage.

Fuel Lines

The sequence of the fittings is critical for correct function of the fuel system. The fuel lines and components are secured using hose clamps.

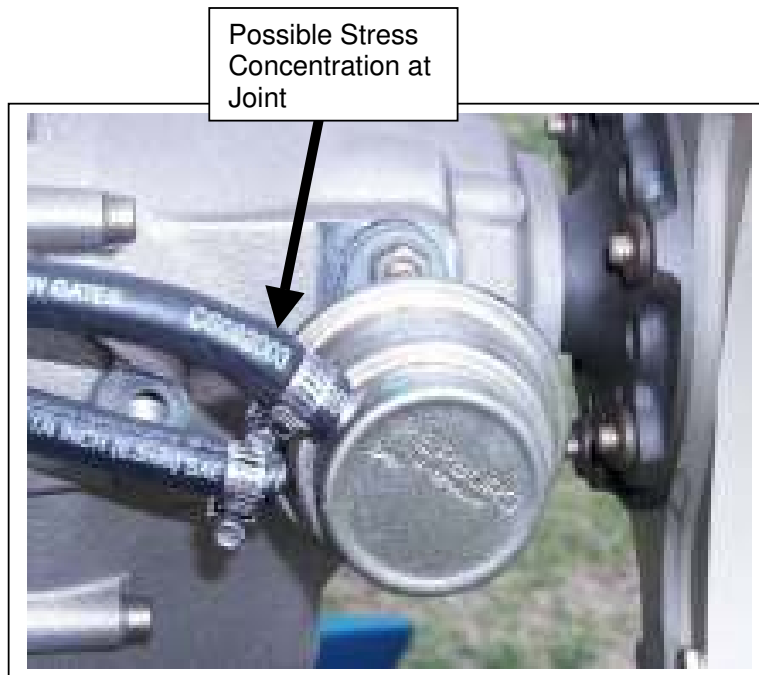

Figure 30 Fuel Line Check Example

Areas that should be checked with extra care are the interfaces between the hose and the motor. These areas are stressed to a greater degree than the rest of the tubing and are more likely to have cracks and or wear. If fuel lines need to be replaced contact Airborne for the correct specifications, and or replacement components.

Fuel Filter

CAUTION

THE FUEL FILTER IS DIRECTIONAL, AND HAS “IN” AND “OUT” MARKED ON IT WHICH IS VERY IMPORTANT. IF THE FUEL FILTER HAS BEEN INSTALLED INCORRECTLY IT SHOULD BE CLEANED PRIOR TO REINSTALLATION, OR REPLACED, TO AVOID DEBRIS BEING FLUSHED INTO THE ENGINE.

The first item after the tank is the fuel filter, correct operation and maintenance is extremely important for reliable operation of the engine. The fuel filter should be removed and checked for debris every 100hrs. The filter should be removed and cleaned at any time debris is seen during the pre flight inspection. If any debris is present the filter may be flushed using fuel to remove the debris. If there is any damage to the filter or there are debris lodged in it then it must be replaced to avoid damage to the engine. If debris is present the rest of the system should be investigated to ascertain their source.

Fuel Meter

CAUTION

THE FUEL METERING DEVICE IS DIRECTIONAL, THE FUEL FLOW IS GIVEN BY THE ARROW ON THE SIDE OF THE METER.

NOTE

Fuel Flow Arrow, which points Downwards in this case.

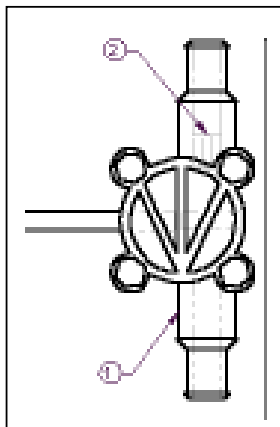

Figure 31 Fuel Flow Sender Device.

The electric fuel meter supplies usage information to the digital readout in the pod.

The fuel meter has two scales of fuel flow reading capability and if removed or renewed the correct settings must be used for the meter to read correctly. This system is able to supply consumption rates and total usage information if the computer is reset after refilling the tank. For remaining fuel it should be used in addition to the visual check, but not instead of. The visual check is described in section 28.40.00 The electrical system and schematic is described in section 8.4 of the Pilots Handbook.

Fuel Meter Maintenance

Check the fuel meter for proper rotation of the impellor and that there are no blockages or debris present. A good time to do this would be during replacement of the fuel lines or filter unit. If there is any debris present at any time then a full investigation of the origin as well as investigation of the fuel filter is absolutely necessary. The fuel filter should have prevented any debris making its way into the meter.

Replacement of the Fuel Sender Device

If the fuel sender device is being replaced then the correct installation of the flow range jet is important. Incorrect installation will cause the unit to malfunction. The jet must be fully inserted in the inlet port, with the smaller diameter end toward the inside. Push it to the inner end with a flat ended rod and tap gently to ensure it is fully seated.

Included is a photograph of a flat ended rod used for installation, the meter, and vernier callipers, the reading for a correctly seated flow range jet is 23.5mm.

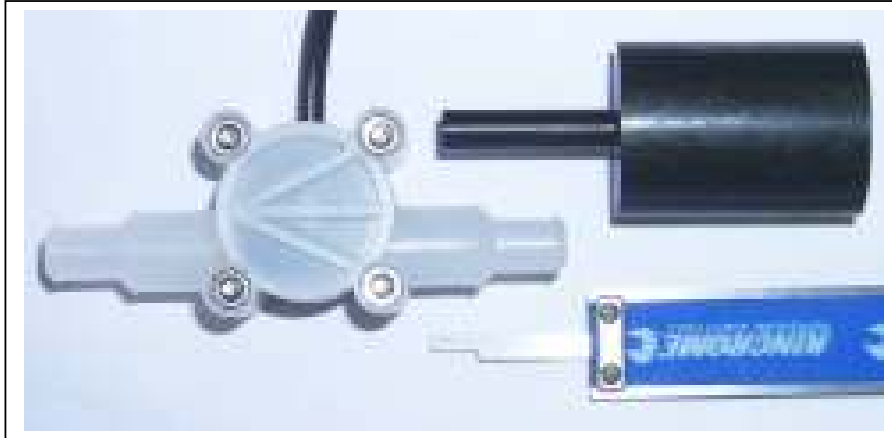

Figure 32 Fuel Sender and tools

Fuel Safety Cut-off Valve

The final component prior to the engine, is the fuel safety cut-off valve which is used both during transportation, and during any fuel or fire emergency to starve the engine of its fuel supply.

Maintenance:

CAUTION

MAKE SURE THAT IF THE SAFETY VALVE IS REMOVED IT IS REINSTALLED TO COMPLY WITH THE OPEN AND CLOSED POSITIONS OF THE PLACARD.

Handle

Make sure that the valves actuating handle is secure.

Flow Checks

Should there be any doubts about the fuel supply to the engine, i.e. a lack of power at any RPM range, then the Safety Cut Off Valve (as well as all other fuel line components) should be checked to ensure that they allow the free flow of fuel. At least one side of the valve should be disconnected and the valve visually inspected in both the open and closed positions. When the valve is open it should be large enough that it will in no way restrict the flow of the fuel. When installed the valve should be closed to starve the engine of fuel to ensure that the valve closes fully – perform this test while on the ground only.

Stiff Operation

Should the valve become stiff to operate it may be dismantled and cleaned as required, however should there be any damage or wear evident, it should be replaced.

Reinstallation

The Loctite thread sealant should only be applied from approximately halfway from the end to the start of the thread, again keeping it from entering the fuel line.

Loose Operation

Ensure that the Safety Valve is not too loose in it's operation. The valve must be firm enough that it requires a positive closing force, and will not be able to vibrate to the closed position.

WARNING

THE REINSTALLATION OF THE FUEL TAP REQUIRES THE USE OF GASOLINE RESISTANT THREAD SEALANT TAPE, AND SPECIAL CARE IS REQUIRED TO PREVENT ANY OF THE TAPE ENTERING THE FUEL LINE. THE WRAP OF THE TAPE NEEDS TO BE IN THE SAME DIRECTION AS THE THREAD, AND MUST BEGIN AWAY FROM THE START OF THE THREAD. THIS PROCEDURE CAUSES THE TAPE TO ONLY BE FORCED FURTHER ONTO THE THREAD DURING INSTALLATION, AND PRECLUDES ANY STRANDS FROM ENTERING THE FUEL LINE.

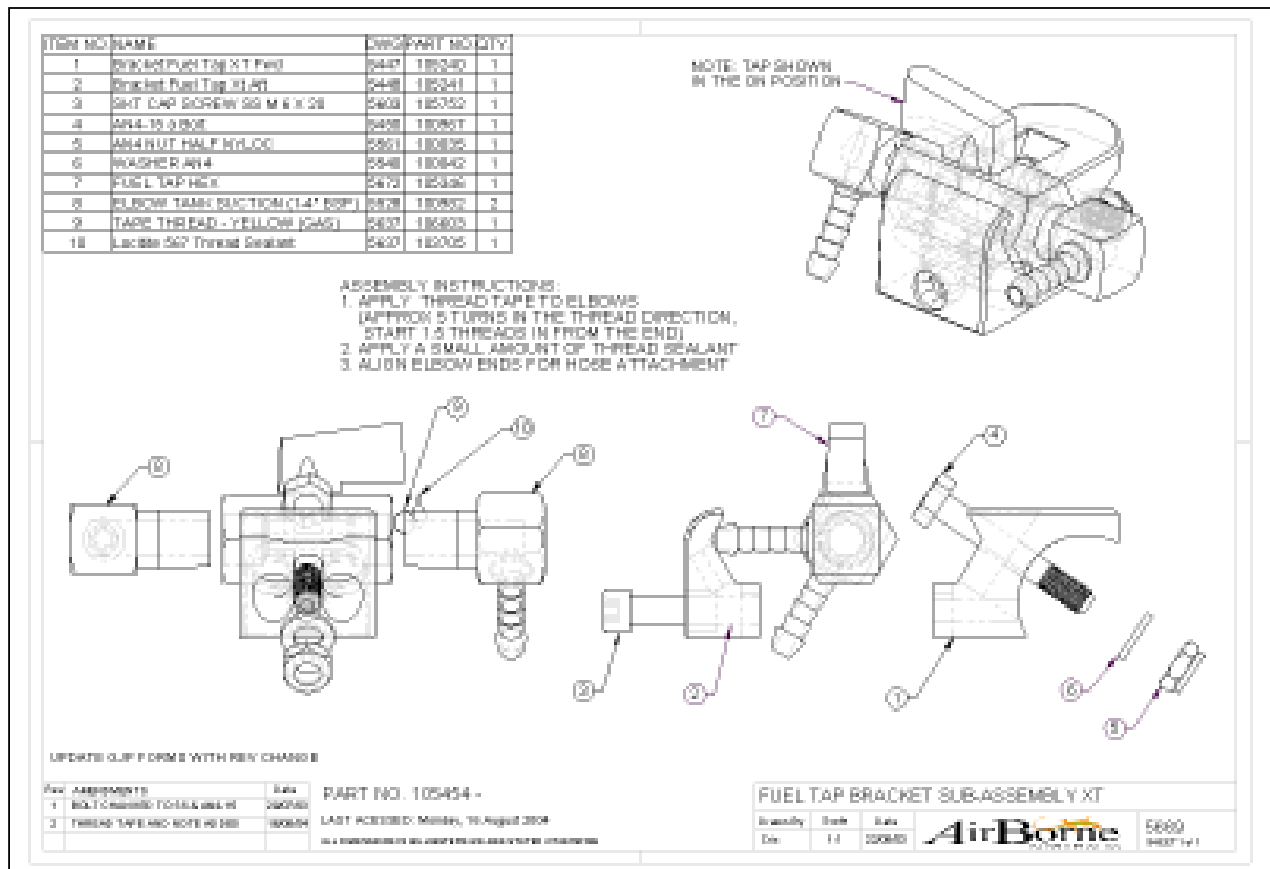

Figure 33 Fuel Tap Bracket Sub Assembly

28.40.00 Indicating

The main fuel level indication method is a visual check of the level on the exposed part of the tank on the right hand side. There are graduations imprinted on the plastic in ten litre increments up to 60 litres, it should be noted they are calibrated for use while the trike is level on the ground. "Zero" fuel level is indicated when the fuel is at the bottom of the sight gauge.

31. INDICATING/RECORDING SYSTEMS

31.00.00 General

This chapter provides a pictorial coverage of the instruments, the instrument panel, and all controls mounted on it.

The instrumentation of the base includes the AMPtronics GX2 Flight instrument and an additional air speed indicator (Calibrated in Knots).

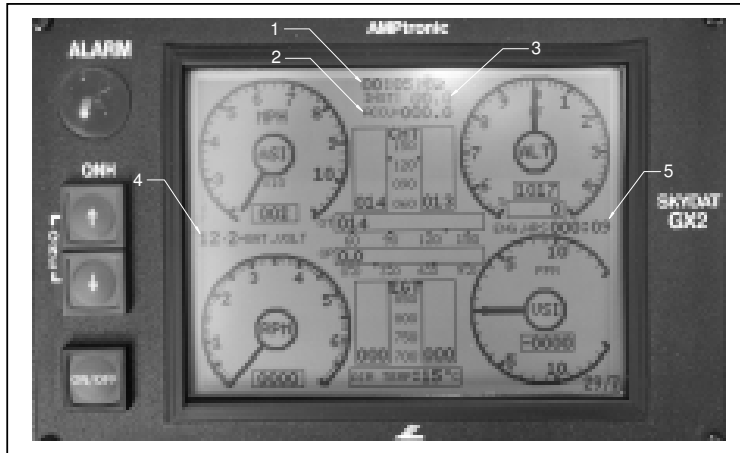

Figure 34 SkyDAT Console Photo

WARNING

IT IS PROHIBITED TO FLY THIS AIRCRAFT WITH THE AMPTRONIC SKYDAT GX2 ALARM THRESHOLDS SET OUTSIDE THE ENGINE MANUFACTURER'S LIMITS.

Features of the Instrumentation:

Standard

ASI mph , knots or kilometres	ALT (Altimeter) in feet or meters
RPM (engine revolutions per minute)	VSI (vertical speed indicator) in m/s or ft/min
Flight duration (1), in hours; minutes; seconds	Battery Voltage (4)
Engine Hours (5), in hours, minutes	2X CHT (cylinder head temperature) Celsius or Fahrenheit
Oil Temperature	2X EGT (exhaust gas temperature) Celsius or Fahrenheit
Oil Pressure, bars or PSI	Air Temperature

Additional air speed indicator (Calibrated in Knots)

Fuel flow data is available.

Accumulative fuel (2) in litres or gallons	Fuel Flow (3) in litres or gallons
--	------------------------------------

Table 14 Features of the Instrumentation

Changing the units of the SkyDAT

The units of the SkyDAT display may be changed to match the units that are used in the country where the display is being used. The method is given in the pilot's handbook, Section 7.16.

31.00.10 Maintenance

There are no user serviceable parts in any of the instrumentation for this aircraft, any maintenance required should be carried out by an approved service centre.

31.10.00 Panels

The panel for the AMPtronics system is included in the pilots handbook, section 3.4. Showing the layout of the display.

31.20.00 Independent Instruments

The additional air speed indicator is an instrument included as a fail safe in case of the failure of the electronic system. The additional air speed indicator is calibrated in knots and has red tags which indicate the VNE speed for the aircraft, the aircraft is placarded in knots so it provides easy reference to VNE information for pilots who prefer other air speed units.

32. LANDING GEAR

32.00.00 *General*

The XT trike base landing gear assembly consists of a tricycle type undercarriage. Both the front and the rear suspension incorporate air shocks that allow pneumatic adjustment of the “spring rate” and fluid flow damping.

32.10.00 *Undercarriage*

General Maintenance

With the weight removed from each wheel, and check each of the components is not loose. Also check each of the bearings, tyre wear and the condition of the brake line.

Where excessive looseness is found the bushes and attachment points should be checked for wear and replaced if necessary. In practice this will mean that any pivot point should not have more than 1/2mm of movement, when load is applied. The main areas that need to be checked for looseness are suspension pivots, the mast pivot, and the main mast pivot hole. For wheel and suspension pivots the wheels should be lifted from the ground when testing the movement.

32.10.10 Structure

Rear

The main (Rear) undercarriage is manufactured from 6061 extruded aluminium tubing which attaches to fittings that in turn attach to the pivot locations. The rear suspension layout consists of tubular main struts for the rear suspension, an airfoil shaped drag link and airfoil shaped rear strut. These are attached to the wheels and the frame via fittings.

The fittings are manufactured from 2011 aluminium and AS 1163 Steel, welded and bolted to the struts and drag link.

Front

The front suspension, steering and braking assembly is manufactured from welded AS 1163 Steel. It is a regular fork type assembly with welded lugs and bushes for all attached parts. The fork carrier assembly has two bearings pressed into it for attachment onto the main frame.

Damage

Both the front and rear undercarriage allow for minor damage that does not result in dimensional changes of the materials (Permanent deformation). Tell tale signs of permanent deformation include chipped paint around highly stressed areas and crazing of the alloy members. Any permanent deformation warrants full checking of all possible effected parts.

32.10.20 Air Shocks

The life of the shocks should exceed that of the aircraft due to the minimal amount of travel they will do on the ground, though they still need to be checked regularly for correct operation. If one of the shocks has lost air then they will sag a different amount on the ground relative to each other.

Rear Shocks

WARNING

THE REAR AIR SHOCKS ARE UNDER VERY HIGH PRESSURE, THEY ARE PRE SET AT THE FACTORY TO 40 BAR, 580 PSI, WHICH WILL REQUIRE SPECIALISED EQUIPMENT TO BE REPRESSURISED.

IF THESE SHOCKS REQUIRE SERVICE OR PRESSURE TESTING CARE SHOULD BE TAKEN TO ENSURE THAT THE CORRECT EQUIPMENT IS AVAILABLE. CONTACT AN AIRBORNE REPRESENTATIVE IF SUCH EQUIPMENT IS NOT AVAILABLE, THE SHOCK MAY NEED TO BE REMOVED AND TAKEN TO A SUITABLE SERVICE PROVIDER FOR ADJUSTMENT OR CHECKING.

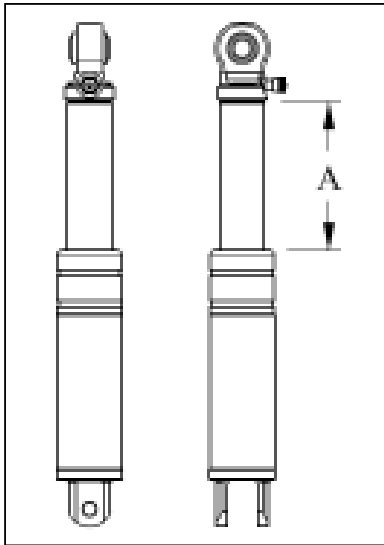

The rear shock absorber should be checked every 100 hours to confirm the dimension of the sliding tubes.

The dimension "A" should not exceed 2mm difference between the right and left shock when the shocks are completely extended ie there must be no weight on the wheels.

If the shocks are outside the nominated tolerance AirBorne should be contacted to organise repair / replacement of the shock unit

Figure 35 Rear Shock Dimension Check

Front Shocks

The front shocks run more user serviceable pressures. There are two reservoirs and a rebound damping adjustment available. The correct procedure for checking the pressures and resetting them if necessary is shown on the following diagram.

The shock absorber should not be adjusted unless it is out of tolerance as indicated on the following diagram.

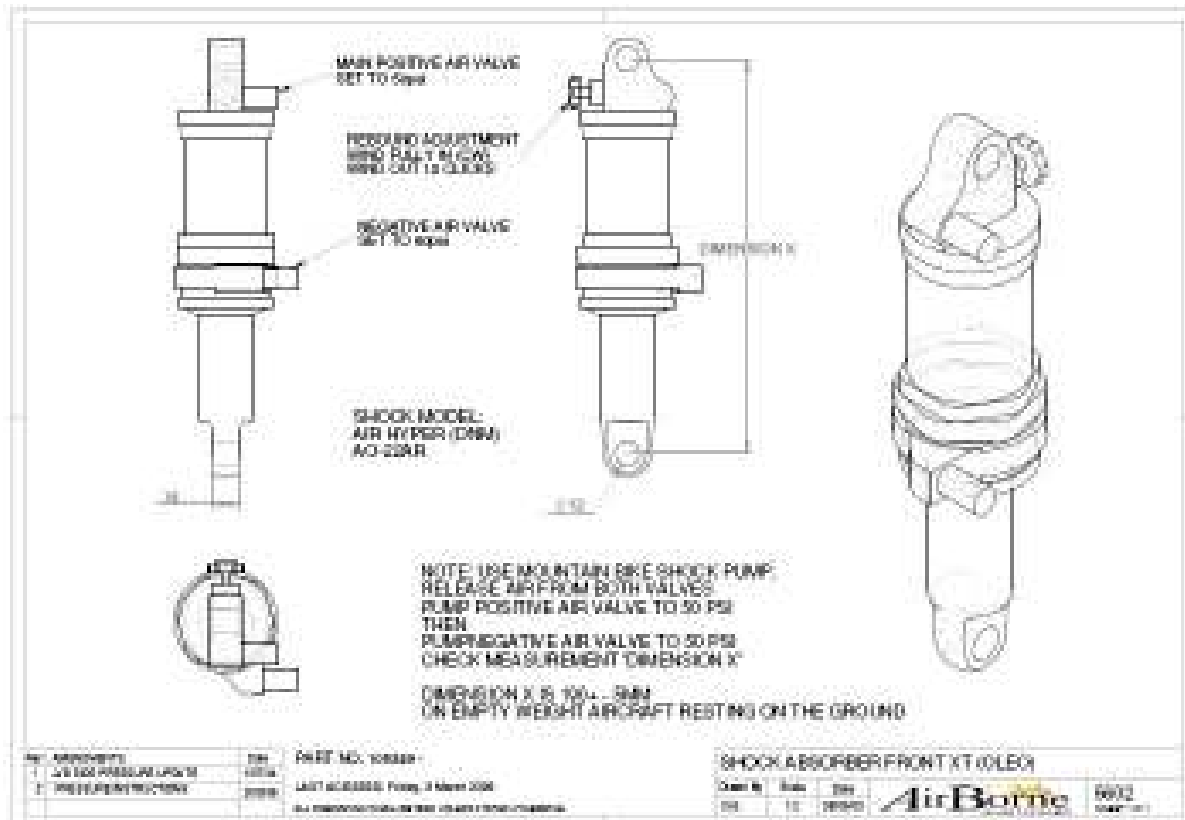

Figure 36 Front Shock Set up

32.20.00 Nose Gear

The front steering is foot activated, and includes a steering damper system. The foot steering system includes a linkage to the rear passenger footrest to allow them to steer if they are piloting. The default setting for the steering damper is light, which is achieved by rotating the shaft of the damper completely in the anticlockwise direction. The setting may be adjusted for personal preference.

WARNING
NEVER ADJUST THE DAMPER WHILE IN FLIGHT AS IT POSSIBLE TO MAKE STEERING DIFFICULT WITH A HIGH LEVEL OF DAMPING (“HEAVY” DAMPING)

Steering Damper Setting

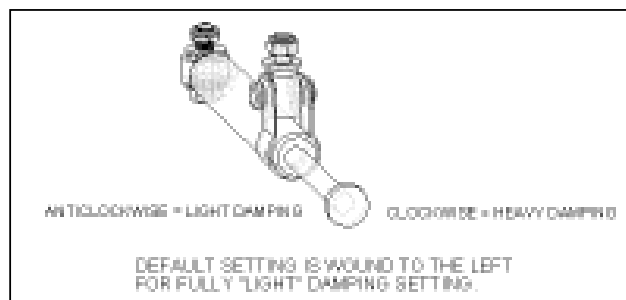

Figure 37 Steering Damper Setting, (Dwg # 5610).

32.40.00 *Wheels and Brakes*

The trike has a single drum style brake on the front wheel. The front wheel and brake assembly is manufactured by Gremica. The brake is cable actuated, and operated via a foot pedal on the left hand side of the steerer.

Brake adjustment and maintenance

The drum brakes on the XT are the same as have been in service on Airborne Trikes for many years and have provided extremely reliable service. The brake pads should be inspected during the 100 hourly inspection of the front wheel bearings. If necessary, the pads should be replaced. As a guide brake pads should be replaced if there is less than 2mm of pad remaining. At the same time the condition of the rim, spokes and other features of the Rim/Brake assembly should be thoroughly inspected for signs of damage or wear.

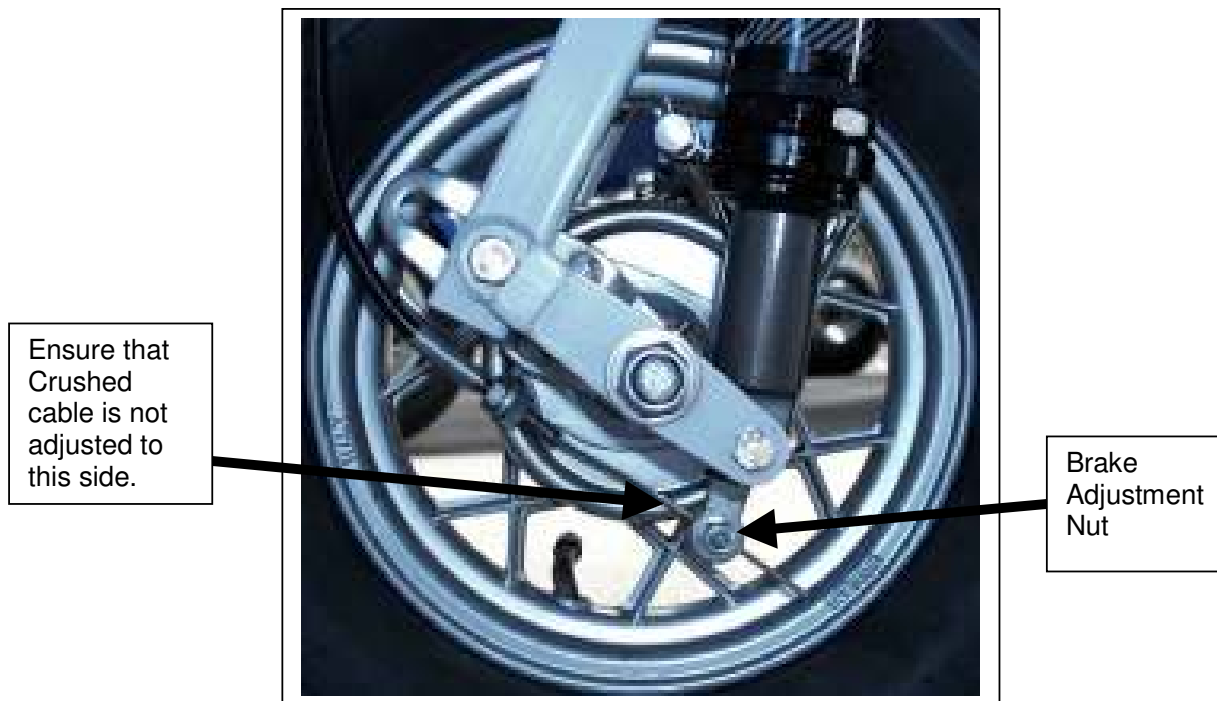

Figure 38 Front Wheel Assembly

The brake depression distance until the brake actuates may be adjusted by loosening the cable attachment point, and moving its position. The cable securing nut must be tightened with sufficient torque to avoid cable slippage. If the attachment point is further towards the end of the cable then the condition of the cable where it was previously clamped should be inspected for deterioration and replaced if necessary. Thoroughly check for free operation of the wheel and proper operation of the brake after adjustment.

Removal of the front wheel

The front wheel should be elevated and the axle nuts removed, care should be taken to note the sequence of removal and subsequent reassembly. The front brake mounting bolt and cable attachment may also need to be removed to release the wheel.

Tyres

Front Tyre

Kenda 4.4 X 4.8 –8 (Nylon) Pressure, 15 Psi.

Rear Tyres

Deestone 15 X 6.00 –6 (Nylon) Pressure, 15 Psi.

When operating on smooth surfaces increased pressure may be desirable, Operator experience and tyre wear pattern may be used as a guide to determine variations to the specified pressures.

When checking tyre pressures, the opportunity should be taken to examine the tyres for wear, cuts, bruises, slippage, and other defects and replaced as necessary.

Because the tyres on the trike contact the runway in an uneven manner, the rear tyres may be swapped with each other in order to utilise all of the tread. This should be done before the tyre becomes worn. It is not ok to have bald or unsafe tyres on one side of a tyre.

32.70.00 *Supplementary Gear*

The brake locking mechanism is used to stop any unwanted movement of the trike while it is on the ground. This is actuated by depressing the brake and moving the latch into one of the grooves. The next time that the brake is depressed the latch will disengage. The latch mechanism should be lubricated with a dry lubricant periodically.

34. NAVIGATION AND PITOT STATIC

34.00.00 General

This chapter provides information on those systems that provide the aircraft navigational data such as the Pitot static system, Airspeed indicator, altimeter, outside air temperature gauge.

34.10.00 Flight Environment Data/Pitot Static

The Pitot Static system for the aircraft has a single entrance at the extreme front of the pod. A single 6mm ID tube travels rearward to a tee intersection. From the splitter a 6mm ID tube continues to the pilots left and to the analogue air speed indicator. A second 3mm tube splits to the pilots right and into the SkyDAT readout. The tubes are both made of PVC and may be replaced if necessary. The length of the tubing is important in order to ensure that any moisture that may be in the tubes will tend to drain out of the front of the Pitot tubes. The other function of the length of the tubes is to ensure that there is less possibility of kinking the tubing. Interference fits are used to keep the tubing in place and some stretching may be required to get new 3mm ID tubing onto the tee intersection fitting.

34.10.10 Maintenance Practices



Figure 39 Dynamic Port (Pitot Entry)

Check that the Pitot port is free from obstruction, or insect nests. The lines may be visually checked from the inside of the Pod for obstructions as the tubing is clear.

CAUTION

ENSURE THAT THE PITOT SYSTEM IS NOT PAINTED OR COVERED OVER AS THE AIRSPEED INDICATORS WILL CEASE TO FUNCTION.

Leaks, moisture and obstructions are the major problems associated with Pitot Static systems. Provided these problems are adequately addressed, the Pitot Static system is essentially maintenance free.

If it becomes necessary to blow through either the Pitot or the Static system in order to clear blockages etc the system should be disconnected at both the instrument ends and blown out with clean, dry air from that end. (Ensure that all lines tee'd into the static system are disconnected).

Avoid blowing through by mouth as this will introduce moisture. Never blow air through from the source end, particularly with the instruments connected, or they will be ruined.

34.10.20 Testing the Pitot System

The Pitot system is to be tested for leaks by applying a pressure at the Pitot head sufficient to cause the airspeed indicator to read 90 knots. There shall be no indication of restrictions in the application of the pressure and no decrease in the reading when the system is sealed for at least 10 seconds.

Testing the Static System

CAUTION

THE PITOT IS A VERY SENSITIVE INSTRUMENT, AND IS EASILY DAMAGED, READ THE INSTRUCTIONS CAREFULLY BEFORE CONTINUING WITH THE TEST PROCEDURE. UNDERSTAND THAT THE AMOUNT OF PRESSURE NEEDED TO TEST THE PITOT IS LOW. NEVER USE COMPRESSED AIR, OR BLOW INTO A PITOT SYSTEM.

Testing the Pitot can be achieved by carefully using a syringe and flexible tube, sealing it to the front of the Pitot entrance and introducing a very small amount of pressure. The amount of pressure is very minimal. At 46.3m/s (90kts) the pressure necessary is only 134mm water or 1.34kPa (0.194PSI). In a 50cc syringe this will equate to somewhere in the region of 2 - 5mm of travel. If the flexible tube is long enough the testing can be done from the cockpit, while looking at the instruments, alternatively a helper will be required.

Outside Air Temperature Gauge

The air temperature reading is taken by the SkyDAT box that is located behind the passenger, above the engine.

Other Instruments:

Other instruments that need to be tested (such as the Air speed indicator and the Altimeter) should be calibrated against an independent instrument, or sent to a service agent for checking and calibration.

53. FUSELAGE

53.00.00 General

The fuselage structure of the XT has a relatively simple design. There are five main components that define the overall structure of the aircraft base. This does not include the Landing Gear, which is included in chapter 32.

53.10.00 Main Frame

There are five main materials that are used in the structure, 6061 T6, Mild Steel, 4130 Steel, JIS G3445 STKM12C, 2011 T6.

The five main components from front to back are:

Fork Carrier

The fork carrier attaches to the front end of the base tube, to it attaches the front landing gear and the front mast brace.

Front Mast Brace

The front mast brace is the stabilising member that joins the front of the trike to the top of the Mast. The Front mast brace is mainly constructed of 6061 T6 Aluminium.

Base Tube

This is the main longitudinal structural beam, to which all of the other structures are attached.

Mast

The mast attaches to the rear of the base tube and provides the main tension member for attachment to the aircraft's wing. It is constructed from 6061 T6 Aluminium.

Engine Mount Structure

The engine mount structure is attached to the rear of the base tube and to the mast. It is constructed mainly from Mild Steel (AS 1163).

53.40.00 Attach Fittings

53.40.10 General

The structures on the fuselage used for the attachment of wings, stabilisers, landing gear, engine and rotor pylons and for the support of equipment within the fuselage, including instrument brackets.

53.40.20 Wings

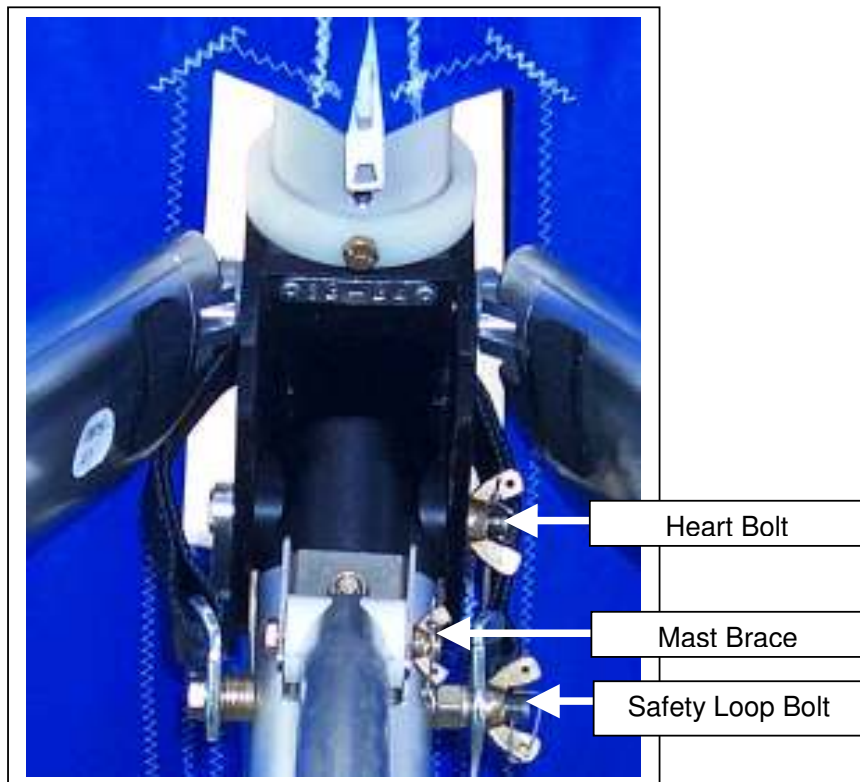

Figure 40 Top of Mast, attached to the wing

The trike base is attached to the wing using an aircraft grade bolt, which attaches to the Wings U bracket. The attachment arrangement allows the mast to move forwards/backwards and sideways relative to the hinge point. There is also the safety strap, included for the unlikely event of the main attachment failing. For instructions regarding the attachment and maintenance of the main bolt, refer to the Wing maintenance manual and the Pilot's Operating Handbook.

53.40.30 Stabilisers

The stabilisers are attached to the frame using the brackets on the inside and outside of the rear wheels. These may be clearly seen in section 20.10.00 Torquing Procedures. They are held in place with Bolts and Washers, where the washers are important to prevent crushing of the composite (AN4 Washers on the outside, and 3/16" X 1/2" washers on the inside). The Illustrated parts catalogue should be consulted for the correct assembly sequence for the spats.

53.40.40 Landing Gear

The landing gear is non retractable. The front landing gear is attached to the main frame through two sealed bearings and bolt assembly. The rear is attached through three bushed pivots, one each for the Drag Link, Rear Strut and Suspension member.



Figure 41 Front Landing Gear Attachment



Figure 42 Front Fork to Wheel Attachment



Figure 43 Rear Landing Gear and Engine Mount Attachment to Mast Block

53.40.50 Engine mount

The engine is attached to the engine mount, which is in turn attached to the mast via the mast block, and to the Base Tube of the aircraft. The engine mount attachment to the mast block can be seen in section 53.30.00 Landing Gear (Above).

NOTE

There are special torques associated with the mast block, and section 20.10.00 Torquing Procedures, should be consulted.

53.40.60 Support of equipment within the Fuselage

1. Seat Attachment

The seats are attached to the mast block, and to the base tube of the trike. At the mast block, they are clamped, and on the base tube the seats are bolted to a bracket which is welded to the base tube.

2. Instrument Brackets

All of the instruments are attached to the aircraft via the fibreglass instrument panel, which is attached to the Pod Fairing area. This panel is attached to the frame using brackets and Nyloc bolts to hold it in place.

53.40.70 Pod Attachment

The pod is attached to the structure using bolts and brackets, and is located on the front mast pole. These attachment points are shown in the photos below.



Figure 44 Pod Front Attachment



Figure 45 Pod Attachment to Mast Brace



Figure 46 Pod Attachment to Seat Frame



Figure 47 Pod Instrument Panel Attachment

53.50.00 Aerodynamic Fairings

The Pod and Spat assemblies are the only included aerodynamic fairing on the aircraft. They are constructed from fibreglass and polyester composite material, and attached to the aircraft via bolts and brackets which attach to the main structure. Each of the fairings should be checked regularly to ensure that the Nyloc bolts are secure, and that the fibreglass where it is attached is in good condition.

55. STABILIZERS

55.00.00 General

The stabiliser system for the XT trike consists of two fibreglass spats, which are attached to the rear wheels of the trike.

55.30.00 Vertical Stabilizers

The vertical stabiliser spats consist of two wheel spats with fins, which protrude from the top surface, and into the airflow, providing some yaw stability at speed. The structural integrity of the spats is important for the wheel operation, and ensuring that the outer wheel nut is secure. They should be checked every 25 hours, as noted in the maintenance schedule, as well as after any hangarage, or transport to check for impact damage that may have occurred.

NOTE

When checking the spats and other fibreglass areas, ensure that they are free from cracks, crushing and delamination that may cause them to come loose.

56. WINDOWS

56.00.00 *General*

The windshield of the XT is basic and should be cared for as per the instructions covered in section 12.20.50.

56.40.00 *Inspection and Observation*

If the windshield becomes damaged it should be replaced. Contact an Airborne dealer.

61. PROPELLERS

61.00.00 General

The XT propeller is a carbon fibre composite, three bladed propeller.

Blade Description: BOS 3 , 68 X 58 SL 3B

Hub/Engine Type: Rotax 912

True Propeller size: 66" (1676.4mm)

Other standard components include:

Hub Block "Base"

Hub Block "Top"

Associated Bolts Washers Nylocs and Washer Plate.

The Propeller is supplied with a product information package that should be read in addition to these instructions.

WARNING

IF THE ENGINE IS TO BE ROTATED AT ANY TIME, IT SHOULD ONLY BE ROTATED IN THE SAME SENSE (DIRECTION) AS IT RUNS. ROTATING THE ENGINE AGAINST THE WAY THAT IT RUNS MAY INTRODUCE AIR INTO THE OIL SUPPLY AND CAUSE DAMAGE TO THE ENGINE.

61.10.00 Propeller Service

61.10.10 Inspection

The intervals at which the propeller must be removed for inspection are specified in the Maintenance Schedule.

With the propeller removed from the aircraft and each of the components separated the blades and boss should be inspected for the sort of damage described below paying particular attention to those

areas which are not visible when the propeller is installed. In addition, the following inspections should be carried out:-

- Bolt holes should be examined for out of round, rough edges, and cracks radiating into the boss.
- Check the whole surface of the hub especially in all areas where there are corners. Make sure the surfaces are clean and there is good lighting. A magnifying glass will aid close inspection.
- Boss faces should be examined for damage where they have been in contact with the hub flanges, particularly at the circumference of the flanges.
- The centre bore should be examined for cracks and delamination of the plies.
- The mounting hub should be examined for corrosion, cracks, correct fit on the crankshaft, and for condition of the attachment bolts and nuts.
- Take note of any sharp nicks, cuts or scratches, as these are stress points from which further problems may occur. Act on them if required. Replace the LE Tape if damaged. Do not operate without LE tape.
- Inspect the propeller and hub in the area around where the prop exits the hub.
- Inspect the bolts, replace if any wear or damage is present.

WARNING

WHEN WORKING ON THE PROPELLER REMOVE THE SPARK PLUG LEADS FROM THE SPARK PLUGS.

61.20.00 Propeller Assembly Procedure

Assemble the propeller components on a flat, soft and clean surface such as a carpet. Before installing a propeller, the propeller shaft and threads should be checked for damage. Boss and hub flange faces should be checked for cleanliness, to ensure that maximum friction will be obtained. Refer to drawing number 5933 in the Illustrated parts catalogue.

The angular position of the propeller on the hub is not important, and the pitch will be set later.

Important Note: All bolts, washers and Nyloc nuts used to clamp the hub plates, and attach propeller assembly to the engine should be assembled dry, without oil or moisture.

61.20.10 Check Material List

- Tie Wire 1 Length as supplied.
- Washer Plate 1
- Hub Blocks Forward/Aft
- Blades 3
- AN4 20A Bolts 6
- AN4 Nyloc Nuts 6
- AN4 Washers (Thin) 6
- AN4 Washers (Thick) 6
- M8 X 75 Drilled 6
- M8 Nyloc Nuts 6 – SUPPLIED IN KIT BUT NOT USED
- M8 Washers 6 – 6 OF 12 SUPPLIED ONLY ARE USED

61.20.20 Assemble Forward Hub Block

The Forward Hub Block is the one which has the larger counterbored holes in it. Put the **THIN** AN4 Washers onto the AN4 Bolts (6 of each) and install into the counterbored holes.



Figure 48 AN4 Bolts Into Forward Hub Block

61.20.30 Place Blades into Forward Hub Block

Place the three blades into the Forward Hub Block, it is best to align them in the general direction they will be rotating in.



Figure 49 Place Blades into Hub Block

61.20.40 Add the rest of the components

The rest of the components that are listed are now added to the Forward Hub Block.

61.20.41 Place the Aft Hub Block onto the Forward Hub Block and over the AN4 Bolts.

61.20.42 Add AN4 **Thick** Washers and then the AN4 Nuts to each of the Bolts – finger tight.

61.20.43 Align the Washer Plate with the Aft Hub Block holes, add the M8 X 75 Drilled Bolts and ONE washer per Bolt, there will be Six washers and Six M8 Nyloc Nuts left over if the Propeller was supplied uninstalled.



Figure 50 Propeller with all the necessary components

61.20.50 Place the pre assembled propeller onto the engines mount

Carefully grip the two Hub Blocks together with your hands and lift from the ground to the engines propeller mount. The M8 Bolts will match the Engines mount pattern. Mate the bolts to the holes while ensuring that the propellers or bolts don't fall. While still holding everything in place finger tighten the bolts in sequence (See the Sequencing in the torquing section). The Propeller should now hold itself in place.



Figure 51 Mounting the Propeller

61.20.60 Nip the AN4 Bolts to allow pitch adjustment

CAUTION

PULL THE BLADE RADially OUTWARDS TO SEAT THE BLADE INTO IT'S HUB BLOCK LOCATION WHILE TIGHTENING THE AN4 NUTS/BOLTS, THIS ENSURES UNIFORM DIAMETRICAL POSITIONING OF THE BLADES RELATIVE TO THE HUB AND EACH OTHER.

Tighten the AN4 Nuts in sequence in order that the propellers can still be easily rotated by hand, but are in a positively held condition, so that they may be adjusted both easily and precisely. Evenly tighten the bolts / nuts in a sequence < bolt 1 – bolt 4 – bolt 2 – bolt 5 – bolt 6 – bolt 3>. Apply the torque to the nuts – not the bolts. Wait until after the Propeller has been adjusted to fully torque either sets of bolts.

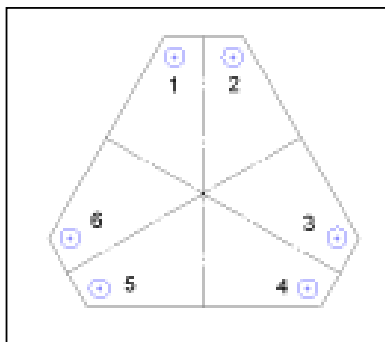

Figure 52 Propeller AN4 Bolt Tightening Sequence Numbers

61.10.20 Adjusting Pitch Angle

The setting for the XT 912 UL is 20 degrees measured on the flat section of the blade at a radius of 24 inches and relative to the flat rear face on the propeller hub. The tolerance on this angle is +/- 0.5 Deg. But should be as close as possible. The best visual clue for this is the mould separation line on the blade – it should be close to the gap between the hub halves at the quoted pitch. The blade angles can be set using a digital level. There are six steps that are required to perform the measurements.

61.10.21 Move the propellers to the approximate pitch position

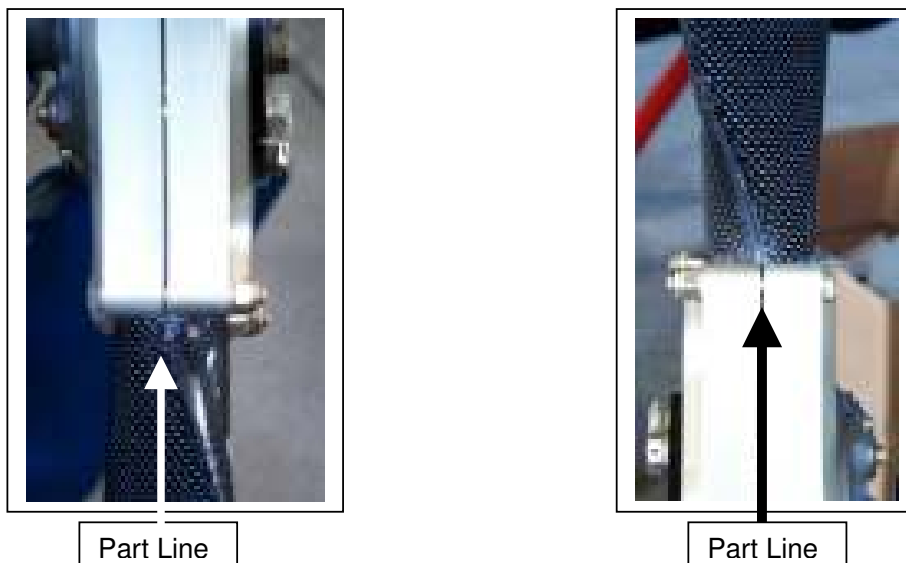

Figure 53 Propeller Part Lines

61.10.22 Ensure Prop Hub is vertical

Level the base of the trike so that the prop hub is vertical. This is achieved by using shims under the front wheel to lift it until the flat surface of the rear of the prop hub is vertical.



Figure 54 Shims under the front wheel



NOTE

The ideal reading is 90 Deg but +/- 0.05 Degrees is acceptable for practical application.

Figure 55 Prop Hub at 89.95 Degrees after correct shimming of front wheel

61.10.23 Rotate the Propeller Blade to be checked to horizontal

The propeller that is to be set should be rotated into position on the pilots right of the engine.

The prop hub vertical surface is checked to be 90 Degrees to ensure the propeller is in the standard horizontal position.

WARNING

IF THE ENGINE IS TO BE ROTATED AT ANY TIME, IT SHOULD ONLY BE ROTATED IN THE SAME SENSE (DIRECTION) AS IT RUNS. ROTATING THE ENGINE AGAINST THE WAY THAT IT RUNS MAY INTRODUCE AIR INTO THE OIL SUPPLY AND CAUSE DAMAGE TO THE ENGINE.

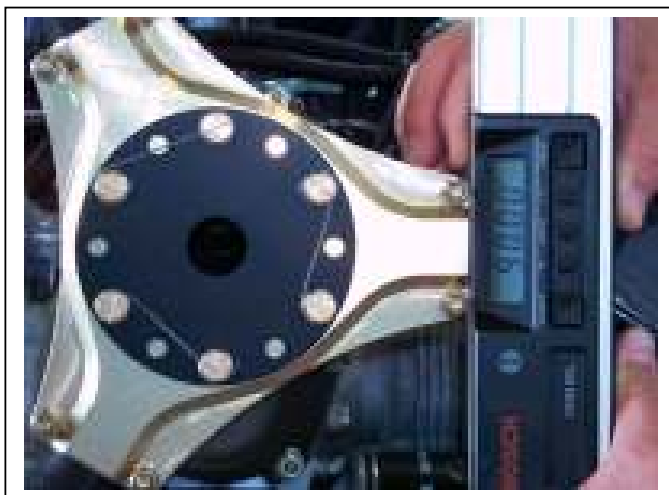

Figure 56 Propeller horizontal check

61.10.24 Measure 24 Inches Radius

The angle of the propeller needs to be checked at 24 inches from the center of the hub. This is the position that the angle of the blade is checked from. Masking tape, or similar should be used to accurately mark the position.



Figure 57 Radius Measurement

61.10.25 Set the angle of the propeller

The angle of the propeller can now be set. Place the digital level in the centre of the 24 inch mark and adjust the pitch of the propeller to 20 Degrees from vertical, or 70 Degrees from horizontal.



Figure 58 Setting the Blade to 70 Degrees at 24 inches

61.10.26 Repeat for the other two blades

Repeat the procedure for the other two blades check thoroughly and then follow the sequence and torquing procedure.

61.10.30 Propeller Bolt Torquing

ONLY after the pitch has been set and confirmed:

Use a calibrated torque wrench, and evenly (side to side) tighten grip bolts, and evenly tighten the bolts / nuts in a sequence < bolt 1 – bolt 4 – bolt 2 – bolt 5 – bolt 6 – bolt 3>. Apply the torque to the nuts – not the bolts.

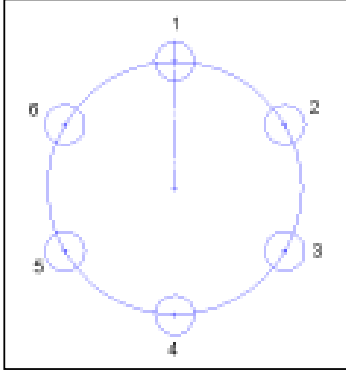

WARNING
ALWAYS TIGHTEN THE BOLTS IN THE
CORRECT SEQUENCE AND TO THE
SPECIFIED TORQUE.

Figure 59 Propeller M8 Bolt Tightening Sequence Numbers

Torque the 1/4" grip bolts to approx 8Nm. Then tighten the engine mounting bolts to the specs below before returning to the grip bolts and finishing at a **maximum** setting of **11 Nm (8 ft-pounds / 95 inch-pounds)**.

If all is well, then proceed to tightening the engine bolts at a **maximum** setting of **13 Nm (9.5 ft-pounds / 115 inch-pounds)**, (assuming the drive plate is threaded 5/16" / M8) and backed up with the tie wire. **DO NOT EXCEED 13 Nm torque. Ensure that the washer plate is installed.** If the washer plate is not installed it is possible that the bolts will become thread bound before applying pressure to the hub, Nyloc nuts should **not** be reused after the final (full torque) check has been completed. Nyloc nuts must have at least one full thread showing after they are installed.

61.10.40 Gap Between Hub Halves

It will be noted that when the hub is bolted together, there is a gap between the halves of nearly 1mm. This is quite deliberate, and will vary slightly as the blade grips are not perfectly circular – generally .6mm higher than wide. This eccentricity will at times cause a slight mismatch on the outside of the hub walls.

The advantage of this gap is that at 13Nm torque settings, the gap will not close. The hub in effect becomes a spring washer, further enhancing mounting assurance. At 13Nm there is a good balance between engine and grip bolt torque settings.

WARNING
CLEARANCE BETWEEN WING WIRES, TUBES, AND THE PROPELLER SHOULD ALWAYS BE MAINTAINED. THIS SHOULD BE CHECKED IN ALL POSSIBLE CONFIGURATIONS OF PROPELLER AND WING.

61.10.50 Tie Wire Installation

Once the torquing has been completed, recheck the pitch of the propellers before moving onto the final tie wire stage.

Tie wire is supplied as a part. Use a tie wire tool to install. The bolts are secured in pairs. Match a length of the tie wire as shown, spin it, leaving approx 20mm at the end to join onto the other bolt in the pair. Attention should be paid to the length, so that there is minimum slack between the two.



Figure 60 Tie Wiring Step 1.

The second step is to thread the last 20mm through the next bolt, spin it and trim the excess. Leave at least ten twists of the tie wire at the end.

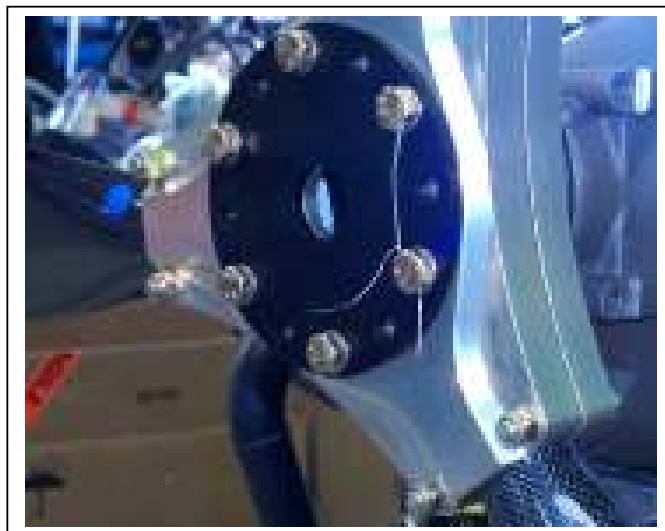

Figure 61 Tie Wiring Step 2.

61.10.30 Final Checks



Figure 62 Correctly Installed Propeller

Recheck the pitch of the propellers after they have been fully torqued. Recheck visually that all components are in place. Note the Tie Wiring.

61.20.00 Blade Damage and Repair

The condition of a composite propeller is important for safe flight. The pilot of the aircraft needs to check the condition of the propeller prior to each flight and ascertain its airworthiness. In general deep scratches across the chord of the propeller are most significant, along with leading edge dents and damage that may lead to delamination.

Leading edge damage is repairable as long as it is not larger than the specified sizes and that the propeller is not delaminated. In general if the damage size on the surface of the propeller is not exceeded then it will be better to leave the surface alone, as filling minor scratches will likely cause more damage. The plies of the propeller are approximately 0.15mm thick each. If any doubts exist as to the condition or repair procedure for the propeller either return the propeller to Airborne, or consult a LAME engineer or equivalent who has experience with composite materials.

61.20.10 Balancing

Balancing of the propeller should not be necessary if the damage allowances are adhered to, repairs should only be to replace what has been removed.

If there is any doubt or if propeller balancing is necessary it is best done by a person who is experienced with composites and with Level 2 LAME qualifications or equivalent. An epoxy compatible, clear spray paint applied at the tips is best, with the surface of the propeller prepared gently with 600 grade sandpaper, and cleaned to remove any oil residue.

61.20.20 Leading Edge Tape

Your propeller blade is supplied with a light grade of Urethane LE Protective Tape applied. This will help resist the abrasive effects of dust, sand & water etc. It will not stop solid objects from damaging the blade, although it will help reduce the damage. If the LE Tape is damaged, it has done its job and will need replacing.

61.20.30 Damage Allowances

All propellers will eventually suffer damage from a variety of causes and in differing degrees of damage. Varieties of damage such as water, stones, gravel & sand makes it very difficult to specify maximum damage levels before the blade should be discarded rather than repaired. For a guide see the FAA Advisory Circular AC 43.13-1B Par 8-71 through 8-109.

The design and construction (unlike wood, metal and many other composite props) is to progressively increase strength from tip to root. As such a solid tip strike is not likely to destroy the hub or root of the blade, (leading to a catastrophic failure), Damage is far more likely at the tip (as tip speed is much higher) but less critical at the tip as it has less forces acting upon it (compared to the root / hub). As all forces are focused on the root and hub sections – these areas are not to be damaged. If any doubt exists as to the airworthiness of a propeller, have it properly assessed prior to flight.

61.20.40 Surface Scratches

The inner 250mm of the prop should not be damaged any further than minor nicks and scratches. This is because it carries the most forces. This area is harder to damage than further out on the radius because the speeds are lower. As a guide there should be no more than three scratches of 0.1mm deep, and 25% of the chord in this area of a blade.

From 250mm out from the hub to the tip of the propeller the depth allowance is slightly greater at 0.15mm and extending a maximum of 25% of the chord. Slightly more damage is allowable toward the tip. There should not be a concentration of scratches in one area.

61.20.50 Leading Edge Damage

Maximum allowed leading edge dent is 3mm within 250mm of the root to 8mm at the tip. The depth of the dents allowable varies linearly from 250mm to 840mm (The Outer Diameter of the Propeller), the equation for the allowable dent is as follows.

1. Measure the location from the prop hub (mm).
2. Depth = 3 + (0.00847 x (Location from Centre – 250)).

The number of dents allowable depends upon their size. It is suggested that two or three per propeller blade would be maximum.

61.20.40 Repair

To repair all dents and scratches a slow cure EPOXY resin must be used. Available from Airborne is a General Purpose Epoxy (180, 360 and 1000gm packs). Damage over 3mm MUST be filled with slurry made from a suitable Epoxy plus fine milled glass fibres (Available from Airborne is a BOS Repair Kit containing the appropriate epoxy, Glass Powder and instructions). For cosmetic scratches and dents use Talc with the epoxy. Always follow the resin instructions and apply to a clean dry surface. When cured, carefully sand the filler back to match the blade apply new LE Tape.

NOTE

If in doubt, or if the propeller has more damage than is able to be fixed by the maintainer then return the propeller to AirBorne for evaluation, possible repair and or overhaul.

Ground Run

After adjustments or maintenance and prior to flight the engine should be run up to check the propeller is functioning normally. The tracking of the propeller should be checked.

The aircraft should be securely chocked and the engine run up to full speed. Ensure the engine temperature is at the required operation temperature. Check that the propeller is functioning normally with minimum vibration. A correctly adjusted propeller should result in the engine being limited to 5000 RPM.

71. POWER PLANT

71.00.00 *General*

This chapter provides information on the installation of the engine, but not the engine itself, or its accessories. Information on these may be found in successive chapters.

71.00.10 *Engine Run Up*

Refer to the pilots operating handbook for run up procedures. The engine should be run up to operating temperature any time that parts or fluids are replaced, or if the engine has been overhauled follow the Rotax instructions in the Rotax manual.

71.00.20 *Engine Removal/Installation*

Engine removal and installation is straight forward and obvious but the following procedure may assist:

Removal

1. Ensure that the emergency fuel shut off valve is OFF.
2. Remove the propeller and mount
3. Disconnect all fluid flexible lines, cap and identify.
4. Disconnect all instrumentation cables from the engine.
5. After the five engine mounts have been undone, the engine may be carefully removed by two people, one on each side, supporting under the cylinder heads. If one person is to perform the operation or if two willing and capable people are unavailable, there are mounting points for a hoist on the top of the engine. The Rotax manual should be consulted for the correct bolt sizes and methods.

While the engine is off

Check the condition of the engine mount, and the engine mount rubbers (See section 71.20.00), replace or repair as necessary.

Installation

The installation of the engine is the reverse of removal. When the exhaust system is rejoined Loctite Antisieze Lubricant should be used on all of the areas that butt into each other. (Loctite # 76764.)

71.20.00 *Mounts*

The engine mount is of welded steel RHS construction. The XT is supported on the engine mount assembly at five points through rubber shock mounts. These shock mounts should be inspected regularly for deterioration, excessive sagging and other damage. It is recommended – but not considered mandatory - that these be replaced at 500 hour intervals. Any damage or distortion to the engine mount structure should be repaired promptly, as apart from any loss of structural integrity, distortion or misalignment of the engine mount structure could impose abnormal stresses on the engine itself.



Figure 63 Engine Mount Rubbers



Figure 64 Top Rubber Link To Gearbox

71.40.00 Attach Fittings

The engine set-up is standard as per Rotax specifications, however there are some simply attached fittings that are extra or necessary.

The SkyDAT data collection

The SkyDAT box is mounted to the top tie rod using a small mounting plate, sticky back Velcro and two zip ties.

Radiator

The radiator is attached to the engine mount assembly via four rubber mounts. These rubber mounts should be checked for any wear of the rubber and replaced as necessary.

Oil Radiator

The oil radiator is attached to the rear of the engine mount with two bolts.

Oil Sump

The oil sump bracket has two bolts attaching it to the engine mount..

Coolant Overflow

The coolant overflow bottle is attached to the engine mount using Velcro straps.

71.50.00 Electrical Harness

The electrical harness for the system is routed between the fuel tank and the engine, it incorporates the engines system, including the start system, and the SkyDAT wiring loom. The wiring loom is easy to find and access. The harness should be checked for security and ensure no wear points. The electrical schematic can be found in the AOI section 7.14.1

71.70.00 Engine Drains

In addition to the fuel tank draincock and the oil sump drain plug there are two engine drains.

The Oil sump has a drain which is routed to the rear of the engine mount at the bottom, near the oil radiator.

The coolant overflow goes down near the mast and exits at the base of the engine mount in the same position as the fuel tank overflow and breather tube.

72. ENGINE MAINTENANCE

Engine Power

Spark plugs should be the type recommended by the manufacturer. Adjusting a carburettor is a specialised job and can have a large effect on the power developed by the engine. Altitude can also affect the power available. When moving to a field with a different elevation it may be necessary to retune the carburettor.

It is recommended that only a qualified person should tune the engine. For Special Light Sport Aircraft maintenance, refer this task to a Mechanic with power plant rating.

72.00.00 General

This aircraft is fitted with a Rotax 912 UL horizontally opposed, four cylinder, water cooled engine. The engine is rated to 59.6 kW maximum take off power with full throttle at 5800 Rpm, and 58 kW maximum continuous speed of 5500 Rpm.

72.00.10 Maintenance and Overhaul

Other than any specific procedures specified elsewhere in this manual, detailed procedures for the maintenance and overhaul of the Rotax 912 UL engine fitted to the XT 912 aircraft can be found in the following documents:

- Rotax Operator Manual for Rotax Engine Type 912 Series
 - Rotax Documentation CD
- Documentation for Rotax engines available at www.rotax-aircraft-engines.com

The supplied manuals and documentation are supplemented by Rotax Service letters and Service Bulletins as appropriate. The Rotax website should be periodically reviewed for these updates.

Overhaul of Rotax engines should be performed by a qualified Rotax service centre. For Special Light Sport Aircraft maintenance, this task must be referred to a Mechanic with powerplant rating and task specific training on Rotax 912 engines.

72.00.20 Carburettor

When checking the carburettor rubbers, check for cracks. There is a Rotax service announcement (1998) which points out that there is a potential issue with the rubbers.

**Rotax
Aircraft Engines
MAINTENANCE MANUAL**

4.7 Inspection of the Carburettor flange socket

Inspection of the carburettor flange socket See fig. 14.

Compress carburettor socket in the area of the carburettor connection to allow easier detection of existing cracks (1) and (3) also check the area of the inner diameter (2). At suspicion of cracks, renew the carburettor flange.

NOTE: The carburettor socket is subject, apart from chemical strain due to fuel and UV radiation, to stress by vibration. Excessive tightening of the clamp may also damage it causing cracks resulting in intake leaks.

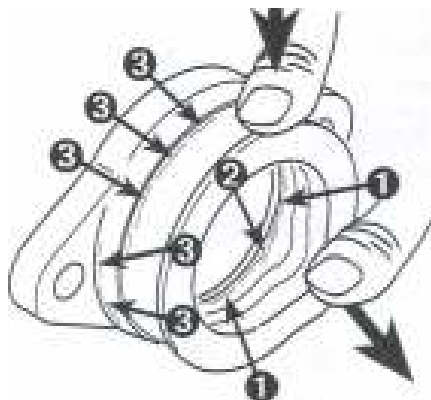

(fig. 14) 00366

Effectivity:912 Series

12-00-00
page 25
Initial issue, Sept. 01/98

Figure 63 Excerpt from Rotax Maintenance Manual Type 912 Series, Edition 0 of 1998 09 01

72.00.30 Radiator

If it is necessary to replace the radiator hoses it is important that the replacement hoses are identical to that supplied with the aircraft. The engine coolant is circulated rapidly through the cooling system and the fitting of hoses other than those supplied can increase flow resistance leading to excessive coolant temperatures. Refer to the Rotax Maintenance Manual for detailed Radiator maintenance, and specific fluids and replacement specifications.

73. ENGINE FUEL SYSTEMS

73.00.00 General

The XT fuel system consists of one fuel tank centrally located underneath and to the rear of the passenger seat of the aircraft. There is one fuel supply line that runs from the left rear of the fuel tank and through to the mechanical fuel pump of the engine. All of the components for the engine are standard as per the Rotax manuals, which should be consulted for maintenance information.

73.20.00 Controlling

The control of the throttle and choke systems for the engine are cable actuated by the pilot. The throttle is situated on the right hand side of the aircraft, and has a double system that is actuated either by foot or hand. The cables from each of the two are routed through a mixer device which allows each to be depressed independently, even if the other is stuck for any reason. The mixer also has two cables from it to the carburettors.

The throttle system has two cables that are both attached to a hand lever on the left hand side of the seat frame.

Carburettor actuation is set up opposite to the standard Rotax sense, this modification is made with no changes to the parts as Rotax provides provision for this alternative set up. Care should be taken to replicate the changes if any Carburettor replacements or overhauls are made.

73.30.00 Indicating

There is a supplementary fuel flow rate sensor that is in line with the fuel supply line. An electrical fuel flow sensor supplies information to the SkyDAT data box mounted on the Tie Rod for the engine. The digital display at the front of the aircraft displays the fuel consumption rate for the pilot. The total usage information is also available if the counter is correctly reset after the fuel tank is filled. The remaining fuel indication should be used in addition to the physical tank graduations that are visible on the pilots right of the fuel tank.

74. IGNITION

74.00.00 General

The power supply of the engine after starting is self sufficient within the engine. No external power supply is require for the engine to operate. The engine generates excess power with the integrated generator, which powers systems, which are external to the engine. The Rotax maintenance manual should be consulted for the maintenance of the engines electrical system. (Section 12.60.00 of the maintenance manual)

74.30.00 Switching

Main Switch

The main switch of the aircraft is located on the front instrument panel, this is used to start the engine, but not to turn it off. There are two wires, which make a double system, that are used to earth the engine stop circuit from the engine. The engines ignition power supply is cut off, stopping the engine.

76. ENGINE CONTROLS

76.00.00 *General*

The fuel supply system of the trike is a cable actuated twin carburettor system.

76.10.00 *Power Control*

Power control is achieved in three ways.

Throttle

There are two methods to actuate the throttle either with the hand throttle or the foot actuated throttle. Both of the cables run through a mixer, which allows each to operate independently. Fully forwards opens the throttle, and fully aft closes the throttle. Section 53.00.00 Landing Gear, clearly shows a photo of the foot throttle pedal.

Choke

There is also a separate choke control, on the left hand side which faces downwards to avoid confusion of the controls.

76.10.10 *Inspection and Maintenance*

In order that the Bowden cables operate correctly they must:

- Not be kinked or damaged
- Be adequately lubricated internally and not binding
- Have the outer properly and securely clamped at both ends
- Have the inners correctly connected to the respective engine linkage and be rotationally free so that the linkage can operate correctly through its full travel without causing binding or bending/kinking of the inner.

Any problems with Bowden type controls can usually be traced to one or more of the above. Rectify the problems as required. If the cable is damaged or kinked in any way it should be replaced. Care must be taken during installation not to kink the replacement cable and to ensure that the routing is correct and will not cause damage or kinking in service.

NOTE

The Throttle cables that are supplied on the XT912 are not user serviceable, though they can be maintained. They are constructed in a special way which allows each of the cables to be actuated independently. If the Throttle cable needs to be replaced and entire throttle cable assembly should be used.

It is difficult to adequately clean the sliding surfaces of an old Bowden cable. It is usually easier to replace them than to attempt maintenance.

After maintenance is necessary to carefully check the operation of the cables, and to ensure that they are correctly secured to the appropriate linkages. Check that the control can be easily operated through its full range of operation.

CAUTION

AFTER THROTTLE CABLES HAVE BEEN ADJUSTED OR REPLACED THE CARBURETTOR SYSTEM WILL NEED TO BE RE SYNCHRONISED, AS PER THE ROTAX METHOD.

76.20.00 *Emergency Shutdown*

Emergency shutdown of the fuel system is either achieved by shutting the motor down, which will stop the mechanical fuel pump, or by moving the main fuel supply tap to the off position which will starve the engine of fuel.

NOTE

There will still be some fuel remaining in the float system of the carburettors if the engine is not starved of fuel to shut it down.

77. ENGINE INDICATING

77.00.00 *General*

The engines operation is monitored by the SkyDAT electronic display system, mounted on the instrument panel. The engine operations monitored are:

RPM (engine revolutions per minute)	Battery Voltage
Flight duration, in hours; minutes; seconds	2X CHT (cylinder head temperature) Celsius or Fahrenheit
Engine Hours, in hours, minutes	2X EGT (exhaust gas temperature) Celsius or Fahrenheit
Oil Temperature	Oil Pressure, bars or PSI

Table 15 SkyDAT Monitored Operations

The normal and maximum operating range for the Oil temperature, exhaust temperature, cylinder head temperature and oil pressure are indicated on the instrumentation and the alarm (Flashing Red Light) will go off if any of the settings are exceeded.

The tachometer does not have an alarm, however the maximum sustained level is 5500rpm, and 5800 rpm should not be run for more than five minutes. The pitch of the propeller set up should prevent over speeding of the engine.

The preset engine limits can be checked against the limits outlined in section 2.4.2 by noting the position of the larger square bars on the LCD display for the particular gauge.

77.10.00 *Power*

The SkyDAT data box collects all of the engine management data.

Tachometer

The tachometer system is connected to the Rotax sensor; the Rotax manual should be consulted for maintenance instructions.

77.20.00 *Temperature*

Cylinder Head Temperature

The cylinder head temperature sensors are supplied with the engine. Information for checking the sender can be found in the following section.

Exhaust Gas Temperature

The exhaust temperature sensors are located at the exit of the two front cylinders of the engine. Information for checking the sender can be found in the following section.

Oil Temperature

The Oil Temperature Sensor is located near the Oil filter at the RHS rear of the engine. The Rotax manual should be consulted for maintenance instructions.

77.30.00 Analysers

Oil Pressure

The Oil pressure indicator sensor is located above the mechanical pump, on the LHS at the rear of the engine.

The SkyDAT instrument will show "open" when there is an open circuit in the CHT circuit.

To determine if the problem is the wiring or the sender simply short-circuit the sender connection to ground at the CHT sender and a message short-circuit should show on the screen for that CHT". This test determines that the wires between the CHT sensor and the SkyDAT are intact.

If there is no "Short Circuit" Signal

If the SkyDAT does not show a short circuit signal, then the wiring between the CHT and the SkyDAT needs to be checked. The best place to start the inspection would be the physical connections, before tracing the wire through. Simply checking the resistance of the wires between each section, as well as to earth (to check for short circuit) will determine the circuit's integrity. Full electrical system analysis instruction is beyond the scope of this manual.

Cylinder Head Temperature (CHT)

A "good" CHT sender measures approximately 800 Ohms (resistance) at room temperature. (when measured between the brass terminal and the block of the engine.) (Remove the red wire from the sender to perform this test) See attached photograph.



Figure 65 Earthing of CHT Sender, to check the wire to the SkyDAT.

Exhaust Gas Temperature (EGT)

If an EGT sender is suspected to be faulty then the best method to check the actual sender is to swap the leads that go into the SkyDat data box. When the engine is operated if the opposite display then shows the same reading as before this will confirm a faulty sender.

To change the wires use the following procedure

1. Obtain a flathead screwdriver with an approx 2mm head.
2. Note the colour of the wires for each position. – Write these down, and preferably mark the left and right hand side EGT wires to make it easy to replace them.
3. Use the small screwdriver to push into the hole above each wire connection, do not force. This releases the wire and allows each to be removed individually.

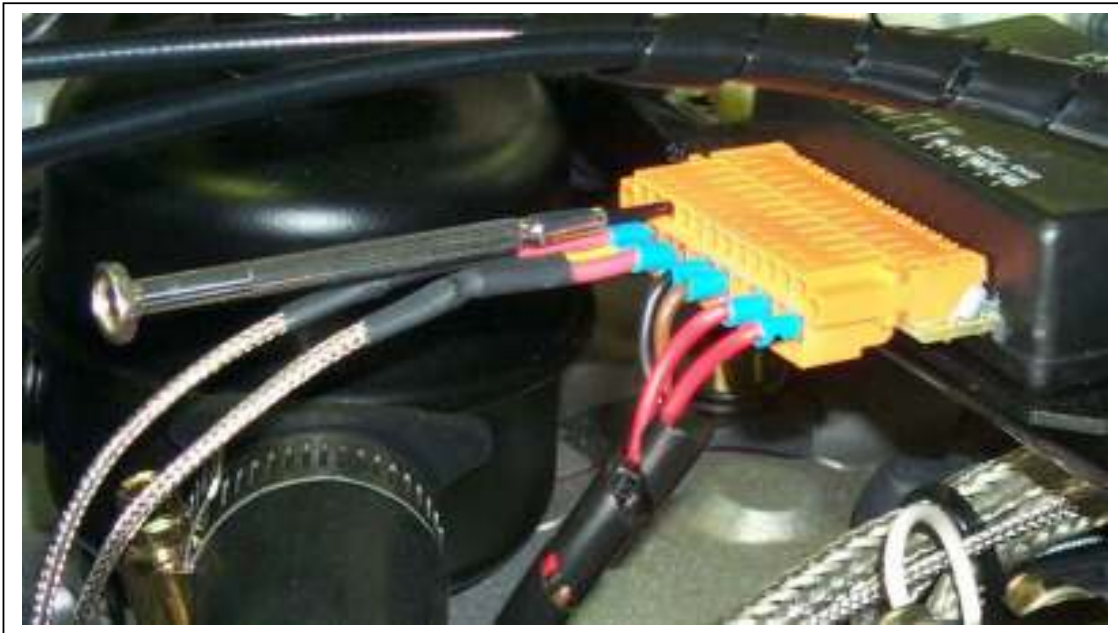

Figure 66 Photo of screwdriver in place to remove wire

4. Remove both sets of wires and place the “Faulty” EGT wires into the side which has been receiving a signal.
5. Now if there is still no signal then the EGT sender needs to be replaced.
6. A further check may be made of the resistance of the sender. Use a multimeter to measure the resistance of the sender. An open circuit clearly shows that the thermocouple circuit is broken and will need to be replaced. Typical values for the resistance of wire are:
RHS Sender – Approximately 1.8 Ohms.
LHS Sender – Approximately 3 Ohms.
7. Order the EGT sender, note that there is a left and right hand side as they are different lengths.

Spare Part
106220– RHS EGT Sender

Figure 67 Spare parts numbers for the XT912

8. Release the wires from the sender that is to be replaced, note the wire routing which is used. Undo the EGT.
9. Replace the EGT, make sure that the copper washer is in place (no sealant is required). The approximate torque for the EGT is 22Nm. Take care not to cross thread.

78. EXHAUST

78.00.00 General

There is one muffler system for the four cylinders. Each of the cylinder exhausts have a custom made manifold that routes to the Rotax Muffler. The exhaust system temperature is indicated by the SkyDAT digital display, with the sensors in place at the exit of the two cylinders to the front of the engine.

78.10.00 Collector/Nozzle

The muffler connections are all of the spring loaded ball joint type to absorb engine vibration. Removal and inspection of the exhaust system is simple and obvious. When reinstalling the exhaust system, Loctite anti seize paste should be used as recommended by Rotax (Loctite # 76764.) See the Rotax manual and Loctite instructions.)

If any minor damage occurs to the exhaust it may be repaired. If new components are required contact an Airborne dealer.

Inspect the general condition of the muffler for corrosion and holes that may be present. Ensure that it is correctly secured with safety and tie wires installed. Check the ceramic coating of the exhaust and replace if it is degraded.

79. OIL

79.00.00 General

The 912 UL engine has an external sump, and the entire system is standard to the Rotax 912 engine. The oil specification is given in the Rotax Operators Manual, Section 10.2.3, Lubricants. In general use only synthetic or semi synthetic oil, API classification "SF" or "SG" or higher quality oils. Multigrade is recommended. These oil types are detergent types. Consult the current Rotax manual for the correct grade of oil for the ambient operating temperature. Refer to Rotax service instruction SI-18-1997 R5, or the latest version.

Oil capacity is : 3 litre (0.8 Us gal)

Dipstick level:

Difference between maximum and minimum oil levels is 0.75 Litre (1.6 liq.pt)

79.10.00 Storage

The oil level is checked by removing the cap on the top of the oil sump and then removing the dip stick type oil level indicator. The oil level should be checked prior to each flight. Refer to Section 12.10.20, Engine Oil System Replenishment for instructions and replacement information.

79.20.00 Distribution

The distribution of the oil is standard to the 912 engine, the Rotax manual should be consulted for maintenance information.

The oil filter that is fitted is a Rotax RB-C308, the filter should be changed at regular intervals as per the maintenance schedules section of this manual in chapter 5.

79.30.00 Indicating

The SkyDAT system has an oil pressure and temperature indicating system and the information is displayed on the SkyDAT Digital readout.

80. STARTING

80.00.00 General

The electrically driven starter motor is mounted on the front left of the engine. A key start is located on the instrument panel. When the master switch is on, pushing the start button will energise the starter system.

The starter system is Rotax standard and the Rotax documentation should be used for the maintenance of the system.

8

95. SPECIAL PURPOSE EQUIPMENT

95.10.00 BRS Parachute System

If a parachute is fitted to this aircraft, a parachute manual will be supplied as a part of the data package. The owner must read the manual, and the manufacturers instructions followed for the maintenance and use of the parachute. The maintenance of the Parachute system shall be recorded in the aircrafts log book.

The BRS system has a single handle that is located just forwards of central on the seat frame. The handle is slightly aft of the choke lever to the pilots left.

Maintenance

The maintenance of the system is limited to ensuring that the attachment point is secure, and that the cable to the BRS rocket and parachute is free from abrasion, and kinking. Also check for any other damage.

The maintenance schedule for the BRS parachute is given in the manual that is supplied with the system, and should be followed to ensure reliable operation of the parachute.

End of XT 912 Maintenance Manual